

GHH RAND®

Teilekatalog

Parts catalogue

Catalogue de pièces détachées

Catalogo di ricambi

Onderdelen catalogus

Edition 5

 **Ingersoll Rand®**

Inhalt / Content / Contenu / Indice / Inhoud

Schüttgut / Dry Bulk / Vrac / Materiale sciolto / Bulkgoederen

CS580 / CS750

Filter / Filters / Filtres / Filtri / Filter

Schalldämpfer / Silencers / Silencieux / Silenziatori / Persdempers

Kühlung & Steuerung / Cooling & controlling / Réfrigération & commande / Refrigeratore & comando / Koeling & controlunits

Konsolen & Antrieb / Brackets & drive / Consoles de montage & commande / Supporti di montaggio & trasmissione / Consoles & aandrijvingen

Diverses / Miscellaneous / Diverse / Diverso / Diversen

CG600

Deckbleche & Verkleidung / Cover plates & casing / Carters & habillage / Lamiere & protezione / Kappen & beschermplaten

Filter / Filters / Filtres / Filtri / Filter

Schalldämpfer / Silencers / Silencieux / Silenziatori / Persdempers

Kühlung & Steuerung / Cooling & controlling / Réfrigération & commande / Refrigeratore & comando / Koeling & controlunits

Konsolen & Antrieb / Brackets & drive / Consoles de montage & commande / Supporti di montaggio & trasmissione / Consoles & aandrijvingen

Diverses / Miscellaneous / Diverse / Diverso / Diversen

CS700

Deckbleche & Verkleidung / Cover plates & casing / Carters & habillage / Lamiere & protezione / Kappen & beschermplaten

Filter / Filters / Filtres / Filtri / Filter

Schalldämpfer / Silencers / Silencieux / Silenziatori / Persdempers

Kühlung & Steuerung / Cooling & controlling / Réfrigération & commande / Refrigeratore & comando / Koeling & controlunits

Konsolen & Antrieb / Brackets & drive / Consoles de montage & commande / Supporti di montaggio & trasmissione / Consoles & aandrijvingen

Diverses / Miscellaneous / Diverse / Diverso / Diversen

CS1050

Deckbleche & Verkleidung / Cover plates & casing / Carters & habillage / Lamiere & protezione / Kappen & beschermplaten

Filter / Filters / Filtres / Filtri / Filter

Schalldämpfer / Silencers / Silencieux / Silenziatori / Persdempers

Kühlung & Steuerung / Cooling & controlling / Réfrigération & commande / Refrigeratore & comando / Koeling & controlunits

Konsolen & Antrieb / Brackets & drive / Consoles de montage & commande / Supporti di montaggio & trasmissione / Consoles & aandrijvingen

Diverses / Miscellaneous / Diverse / Diverso / Diversen

CS1200

Deckbleche & Verkleidung / Cover plates & casing / Carters & habillage / Lamiere & protezione / Kappen & beschermplaten

Filter / Filters / Filtres / Filtri / Filter

Schalldämpfer / Silencers / Silencieux / Silenziatori / Persdempers

Kühlung & Steuerung / Cooling & controlling / Réfrigération & commande / Refrigeratore & comando / Koeling & controlunits

Konsolen & Antrieb / Brackets & drive / Consoles de montage & commande / Supporti di montaggio & trasmissione / Consoles & aandrijvingen

Diverses / Miscellaneous / Diverse / Diverso / Diversen

Kompressoren / Compressors / Compresseurs / Compressori / Compressors

Kompressorzubehör / Accessories / Accessoires / Accessori / Toebehoren

Schmierstoffe / Lubricants / Huiles / Lubrificanti / Smeermiddelen

Keilriemen / V-belts / Courroies trapézoidale / Cinghia trapezoidale / V-snaren

Keilriemenscheiben / V-belt pulleys / Poulies / Pulegge / V-snaar schijven

Taper-Lock-Buchsen / Taper-Lock plug sockets / Taper-Lock-Prise femelle / Taper-Lock prese /

Taper-Lockbussen

Flüssigkeiten / Liquid Bulk / Liquides / Materiale fluido / Vloeistoffen

Drehschieberkompressor SV120/SV200 / Sliding vane compressor SV120/SV200 / Compresseur à palettes SV120/SV200 / Privo d'olio sliding vane compressor SV120/SV200 / Olie vrije schotten compressor SV120/SV200



Schüttgut

*Dry bulk / Vrac /
Materiale sciolto /
Bulkgoederen*



CS580/
CS750

<p>24050122</p> 	<ul style="list-style-type: none"> • Flachdichtung, saugseitig • Flat gasket, suction side • Joint de bride côté aspiration • Guarnizione • Paking 	<p>C24050122</p> <p>CS580 / CS750 Light PTO L Light PTO R</p>	
<p>24044844</p> 	<ul style="list-style-type: none"> • Schlauchanschlussflansch DN100 • Hose connection flange DN100 	<p>C24044844</p> <p>CS580 Light PTO L Light PTO R</p>	
<p>24493348</p> 	<ul style="list-style-type: none"> • Schlauchanschlussflansch DN110 • Hose connection flange DN110 	<p>C24493348</p> <p>CS750 Light PTO L Light PTO R</p>	
<p>22968911</p> 	<p>C22968911</p> <ul style="list-style-type: none"> • Luftansaugfilter Europiclou mit Regenkappe (12 m³/min.) • Suction air filter Europiclou with rain cap <p>CS580 Light PTO L Light PTO R</p>	<p>23266562</p> 	<p>C23266562</p> <ul style="list-style-type: none"> • Luftansaugfilter Europiclou mit Regenkappe (15 m³/min.) • Suction air filter Europiclou with rain cap <p>CS750 Light PTO L Light PTO R</p>
<p>22968937</p> 	<p>C22968937</p> <ul style="list-style-type: none"> • Filterpatrone für Luftfilter 22968911 • Filter cartridge for air filter • Element filtrant pour filtre d'air • Cartucce per filtro aria • Filterelement voor luchtfilter <p>CS580 Light PTO L Light PTO R</p>	<p>23536089</p> 	<p>C23536089</p> <ul style="list-style-type: none"> • Filterpatrone für Luftfilter 23266562 • Filter cartridge for air filter • Element filtrant pour filtre d'air • Cartucce per filtro aria • Filterelement voor luchtfilter <p>CS750 Light PTO L Light PTO R</p>
<p>22968929</p> 	<p>C22968929</p> <ul style="list-style-type: none"> • Halter für Luftfilter 22968911 • Holder for air filter • Cadre support pour filtre d'air • Manicotti per filtro aria • Luchtfiltersteunen voor luchtfilter <p>CS580 Light PTO L Light PTO R</p>	<p>23266604</p> 	<p>C23266604</p> <ul style="list-style-type: none"> • Halter für Luftfilter 23266562 • Holder for air filter • Cadre support pour filtre d'air • Manicotti per filtro aria • Luchtfiltersteunen voor luchtfilter <p>CS750 Light PTO L Light PTO R</p>

<p>23280233</p>  <ul style="list-style-type: none"> • Spiralschlauch DN100 • Flexible hose • Tuyaux flexible • Tubo flessibile • Spiraalslang 	<p>C23280233</p> <p>CS580 Light PTO L Light PTO R</p>	<p>22480602</p>  <ul style="list-style-type: none"> • Spiralschlauch DN110 • Flexible hose • Tuyaux flexible • Tubo flessibile • Spiraalslang 	<p>C22480602</p> <p>CS750 Light PTO L Light PTO R</p>
<p>23394497</p>  <ul style="list-style-type: none"> • Gummibogen 90°, d=101,5 • Rubber elbow 	<p>C23394497</p> <p>CS580 Light PTO L Light PTO R</p>	<p>24585739</p>  <ul style="list-style-type: none"> • Gummibogen 90°, d=110 • Rubber elbow 	<p>C24585739</p> <p>CS750 Light PTO L Light PTO R</p>
<p>22682132</p>  <ul style="list-style-type: none"> • Schlauchschelle 90–110 • Hose clip • Collier de serrage • Cravatta fermatubi • Slangeklem 	<p>C22682132</p> <p>CS580 Light PTO L Light PTO R</p>	<p>22480834</p>  <ul style="list-style-type: none"> • Schlauchschelle 110–130 • Hose clip • Collier de serrage • Cravatta fermatubi • Slangeklem 	<p>C22480834</p> <p>CS750 Light PTO L Light PTO R</p>
<p>23525876</p>  <ul style="list-style-type: none"> • Rohr ALU DN100x2 L=80mm • Pipe, alum. 	<p>C23525876</p> <p>CS580 Light PTO L Light PTO R</p>	<p>23420748</p>  <ul style="list-style-type: none"> • HT Rohr DN110 (lfd. m.) • HT-pipe (per meter) 	<p>C23420748</p> <p>CS750 Light PTO L Light PTO R</p>
<p>24059263</p>  <ul style="list-style-type: none"> • Luftfilter PSD 9–13m³/min (90°) • Air filter PSD 9–13m³/min (90°) 	<p>C24059263</p> <p>CS580 / CS750 Light PTO L Light PTO R</p>	<p>24865073</p>  <ul style="list-style-type: none"> • Filterpatrone für PSD-Serie (9-13m³/min) • Filter cartridge for PSD series • Element filtrant pour PSD • Cartucce per filtro aria PSD • Filterelement voor PSD 	<p>C24865073</p> <p>CS580 / CS750 Light PTO L Light PTO R</p>
<p>24667370</p>  <ul style="list-style-type: none"> • Logoblech für 24059263 • Logo sign for 24059263 	<p>C24667370</p> <p>CS580 / CS750 Light PTO L Light PTO R</p>		

<p>24058695</p> 	<p>• Flachdichtung seitlicher Druckausgangsdeckel • Flat gasket pressure outlet cover side</p>	<p>C24058695</p> <p>CS580 / CS750 Light PTO L Light PTO R</p>	
<p>24054306</p> 	<p>• Flachdichtung, druckseitig • Flat gasket, discharge side • Joint de bride côté refoulement • Guarnizione • Pakking</p>	<p>C24054306</p> <p>CS580 / CS750 Light PTO L Light PTO R</p>	
<p>24336190</p> 	<p>C24336190</p> <p>CS580 Light PTO L Light PTO R</p>	<p>24058679</p> 	<p>C24058679</p> <p>CS750 Light PTO L Light PTO R</p>
<p>22480560</p> 	<p>C22480560</p> <p>CS580 / CS750 Light PTO L Light PTO R</p>	<p>22554794</p> 	<p>C22554794</p> <p>CS580 / CS750 Light PTO L Light PTO R</p>
<p>22487623</p> 	<p>C22487623</p> <p>CS580 / CS750 Light PTO L Light PTO R</p>		
<p>24058687</p> 	<p>C24058687</p> <p>CS580 / CS750 Light PTO L Light PTO R</p>	<p>22486443</p> 	<p>C22486443</p> <p>CS580 / CS750 Light PTO L Light PTO R</p>

83901289GHH



- Sicherheitsventil G 1 1/2", 2,6 bar
- Safety relief valve
- Soupape de sûreté
- Valvola di sicurezza
- Overdrukventiel

83901289

CS580 /
CS750
Light PTO L
Light PTO R

24327850





- Schutzhaube für Sicherheitsventil G 1 1/2"
- Protection cover for safety relief valve

C24327850

CS580 /
CS750
Light PTO L
Light PTO R

15452GHH		15452	
	<ul style="list-style-type: none"> • Armatureträger • Control board • Console de contrôle • Controllo con indicatore • Controle unit 	CS580 / CS750 Light PTO L Light PTO R	
83903302GHH		83903302	22787980
	<ul style="list-style-type: none"> • Wartungsanzeiger • Maintenance indicator • Indicateur d'entretien • Indicatore per manutenzione • Onderhoudsindicator 	CS580 / CS750 Light PTO L Light PTO R	 <ul style="list-style-type: none"> • Rohrfedermanometer für Öldruck 0-4 bar, Anschluss unten • Oil pressure gauge 0-4 bar, connection at bottom • Manomètre de pression d'huile • Manometro pressione olio • Oljedrukmeter
22480800		C22480800	22480867
	<ul style="list-style-type: none"> • Schraubhülse • Collet • Coquille • Conchiglia • Huls 	CS580 / CS750 Light PTO L Light PTO R	 <ul style="list-style-type: none"> • Verschraubung • Fitting • Raccord • Raccordo • Fitting
23550023		C23550023	
	<ul style="list-style-type: none"> • Verschraubung GE 6 LM ED M12x1,5 • Fitting • Raccord • Raccordo • Fitting 	CS580 / CS750 Light PTO L Light PTO R	
23937394		C23937394	
	<ul style="list-style-type: none"> • Verschraubung Rohrstützen für Leitung mit Sicherungsring • Fitting pipe connection for pipe with safety ring 	CS580 / CS750 Light PTO L Light PTO R	
23937527		C23937527	
	<ul style="list-style-type: none"> • Einsteckverschraubung gerade M10x1K, 6mm mit Raste • Plug and socket connection M10x1K, 6mm with pawl 	CS580 / CS750 Light PTO L Light PTO R	

<p>22480594</p> 	<p>• Schlauch/Hochdruck 8,6 x 4,0mm • High pressure hose • Tuyaux pour haute pression • Tubo per alta pressione • Hogedrukslang</p>	<p>C22480594</p> <p>CS580 / CS750 Light PTO L Light PTO R</p>	
<p>23519002</p>  <p>• Regenkappe für Kühlluft-ansaugleitung • Rain cap for cooling air suction pipe</p>	<p>C23519002</p> <p>CS580/ CS750 Light PTO L Light PTO R</p>	<p>22480834</p>  <p>• Schlauchschelle 110–130 • Hose clip • Collier de serrage • Cravatta fermatubi • Slangeklem</p>	<p>C22480834</p> <p>CS580/ CS750 Light PTO L Light PTO R</p>
<p>23420748</p>  <p>• HT Rohr DN110 (lfd. m.) • HT-pipe (per meter)</p>	<p>C23420748</p> <p>CS580 / CS750 Light PTO L Light PTO R</p>	<p>22480602</p>  <p>• Spiralschlauch DN110 • Flexible hose • Tuyaux flexible • Tubo flessibile • Spiraalslang</p>	<p>C22480602</p> <p>CS580 / CS750 Light PTO L Light PTO R</p>
<p>24575912</p> 	<p>• Befestigungsschelle für HT-Rohr DN110 • Fastening clip for HT-pipe</p>	<p>C24575912</p> <p>CS580 / CS750 Light PTO L Light PTO R</p>	
<p>23367576</p> 	<p>• Lüfter-Relais-Steuerung (1 Lüfter) inkl. Kabel • Fan relay control unit (1 fan) incl. cable</p>	<p>C23367576</p> <p>CS580 / CS750 Light PTO L Light PTO R Remote cooler</p>	
<p>23373764</p> 	<p>• Lüfter-Relais-Steuerung (2 Lüfter) inkl. Kabel • Fan relay control unit (2 fans) incl. cable</p>	<p>C23373764</p> <p>CS580 / CS750 Light PTO L Light PTO R Remote cooler</p>	

<p>11697GHH</p>  <ul style="list-style-type: none"> • Ölkühler T1 mit Lüfter 24 Volt • Oil cooler T1 with fan 24 Volt 	<p>11697</p> <p>CS580 / CS750 Light PTO L Light PTO R Remote cooler</p>	<p>13436GHH</p>  <ul style="list-style-type: none"> • Reduzierschraubung RI 1" ED-1/4 (Einsatzmenge: 2 pro Kompressor) • Reducer connector (Req. quantity: 2 per compressor) 	<p>13436</p> <p>CS580 / CS750 Light PTO L Light PTO R Remote cooler</p>
<p>22669055</p>  <ul style="list-style-type: none"> • Einschraubverschraubung, gerade GE 10-PLR-1/4 ED (Einsatzmenge: 2 pro Kompressor) • Male end fitting, straight (Req. quantity: 2 per compressor) 	<p>C22669055</p> <p>CS580 / CS750 Light PTO L Light PTO R Remote cooler</p>	<p>22775027</p>  <ul style="list-style-type: none"> • Winkel-Verschraubung EVW-L-06 • Angle fitting EVW-L-06 	<p>C22775027</p> <p>CS580 / CS750 Light PTO L Light PTO R Remote cooler</p>
<p>15551GHH</p>  <ul style="list-style-type: none"> • Öldruckschalter 0,5 bar • Oil pressure switch • Interrupteur à pression d'huile • Interruttore per pressione d'olio • Oiledrukschakelaar 	<p>15551</p> <p>CS580 / CS750 Light PTO L Light PTO R Remote cooler</p>	<p>23100563</p>  <ul style="list-style-type: none"> • Schutzkappe für Öldruckschalter • Protection cap for oil pressure switch 	<p>C23100563</p> <p>CS580 / CS750 Light PTO L Light PTO R Remote cooler</p>
<p>24529760</p>  <ul style="list-style-type: none"> • Schwenkverschraubung SWVE 12 LM 18x1,5 auf 10L (Einsatzmenge: 2 pro Kompressor) • Swiveling screw fitting SWVE 12 LM 18x1,5 to 10L (Req. quantity: 2 per compressor) 	<p>C24529760</p> <p>CS580 / CS750 Light PTO L Light PTO R Remote cooler</p>	<p>10446GHH</p>  <ul style="list-style-type: none"> • T-Stück für Öldruckschalter • T-piece for oil pressure switch 	<p>10446</p> <p>CS580 / CS750 Light PTO L Light PTO R Remote cooler</p>

<p>24099657</p>  <ul style="list-style-type: none"> • Konsole Universal • Universal bracket 	<p>C24099657</p> <p>CS580 / CS750 Light PTO L Light PTO R</p>	<p>24315814</p>  <ul style="list-style-type: none"> • Konsole DAF CF 85 • Bracket DAF CF 85 	<p>C24315814</p> <p>CS580 / CS750 Light PTO L Light PTO R</p>
<p>24322638</p>  <ul style="list-style-type: none"> • Konsole MAN 6x2 • Bracket MAN 6x2 	<p>C24322638</p> <p>CS580 / CS750 Light PTO L Light PTO R</p>	<p>47604623001</p>  <ul style="list-style-type: none"> • Konsole MAN 4,5° • Bracket MAN 4,5° 	<p>N/A</p> <p>CS580 / CS750 Light PTO L Light PTO R</p>
<p>24325557</p> 		<ul style="list-style-type: none"> • Ausgleichskeile-Kit für Actros 3/Axor/DAF • Angle shim kit 	<p>C24325557</p> <p>CS580 / CS750 Light PTO L Light PTO R</p>
<p>24325524</p> 		<ul style="list-style-type: none"> • Ausgleichskeile-Kit für an Scania (2.7°) • Angle shim kit 	<p>C24325524</p> <p>CS580 / CS750 Light PTO L Light PTO R</p>
<p>24325540</p> 		<ul style="list-style-type: none"> • Ausgleichskeile-Kit für an MAN (4.5°) • Angle shim kit 	<p>C24325540</p> <p>CS580 / CS750 Light PTO L Light PTO R</p>
<p>Diverse</p> 		<ul style="list-style-type: none"> • Distanzstück-Kits / Spacer kits: • 47583894001 (20 mm) • 47583895001 (10 mm) 	<p>C24324469</p> <p>CS580 / CS750 Light PTO L Light PTO R</p>











22480701 	<ul style="list-style-type: none">• Festkupplung Storz B 2,5" IG ALU• Storz coupling B 2.5" female thread, alum.• Accouplement Storz B• Accoppiamento Storz B• Koppeling Storz B	C22480701 CS580 / CS750 Light PTO L Light PTO R
22480693 	<ul style="list-style-type: none">• Blindeckel mit Kette Storz B• Blind cap with chain Storz B• Couvercle aveugle avec chaîne Storz B• Coperchio con catena Storz B• Blindkap met ketting Storz B	C22480693 CS580 / CS750 Light PTO L Light PTO R
22952337 	<ul style="list-style-type: none">• Festkupplung mit Arretierung LM franz. Gr. 80 2,5" IG• Coupling LM French size 80 2.5" female thread	C22952337 CS580 / CS750 Light PTO L Light PTO R
22914147 	<ul style="list-style-type: none">• Festkupplung, Blindeckel LM franz. Gr. 80• Blind cap LM French size 80• Couvercle aveugle LM dim. francaise 80• Coperchio LM francese dim. 80• Koppeling met blindkap Frans maat 80	C22914147 CS580 / CS750 Light PTO L Light PTO R
23875958 	<ul style="list-style-type: none">• Reibkupplung RCP40 800Nm• Friction coupling RCP40 800Nm	C23875958 CS580 / CS750 Light PTO L Light PTO R
23308059 	<ul style="list-style-type: none">• Distanzring DN40 x 60 x 5mm für Reibkupplung RCP40• Spacer DN40 x 60 x 5mm for friction coupling RCP40	C23308059 CS580 / CS750 Light PTO L Light PTO R









23641368 	<ul style="list-style-type: none">• Überlastkupplung Typ W37-B, grün (g)• Shear bolt coupling, green (g)	C23641368 CS580 / CS750 Light PTO L Light PTO R
22626568 	<ul style="list-style-type: none">• Gelenkwellenflansch DIN 100-6/8 d=40H7• Companion flange	C22626568 CS580 / CS750 Light PTO L Light PTO R
23462385 	<ul style="list-style-type: none">• Scherbolzen, 1 Stück, grün (g)• Shear bolt, 1 piece, green (g)	C23462385 CS580 / CS750 Light PTO L Light PTO R









<p>24047060</p> 	<ul style="list-style-type: none"> • Anschlussglocke Hydraulikmotor • Trunk for hydraulic motor 	<p>C24047060</p> <p>Hydraulic kit 24050320</p> <p>Hydraulic kit 24579716 (incl. motor)</p>	
<p>24049512</p> 	<ul style="list-style-type: none"> • Abdeckung Hydraulikantrieb • Cover hydraulic drive 	<p>C24049512</p> <p>Hydraulic kit 24050320</p> <p>Hydraulic kit 24579716 (incl. motor)</p>	
<p>24887689</p> 	<ul style="list-style-type: none"> • Kupplung-Einheit, drehelastisch, mit Zwischenwelle • Coupling package, torsionally flexible, with intermediate shaft 	<p>C24887689</p> <p>Hydraulic kit 24050320</p> <p>Hydraulic kit 24579716 (incl. motor)</p>	
<p>24050171</p> 	<ul style="list-style-type: none"> • Zahnkranz 38, 64 Shore (Einsatzmenge: 2 pro Antrieb) • Geared rim 38, 64 Shore, (Req. quantity: 2 per drive) 	<p>C24050171</p> <p>Hydraulic kit 24050320</p> <p>Hydraulic kit 24579716 (incl. motor)</p>	
<p>23501547</p>  <ul style="list-style-type: none"> • Ölansaugsieb • Oil suction filter • Filtre d'huile admettre • Filtro d'olio • Olieaanzuigfilter 	<p>63479000</p> <p>CS90</p>	<p>23200504</p>  <ul style="list-style-type: none"> • Deckel mit Entlüftung • Cap with breather 	<p>C23200504</p> <p>CS90</p>





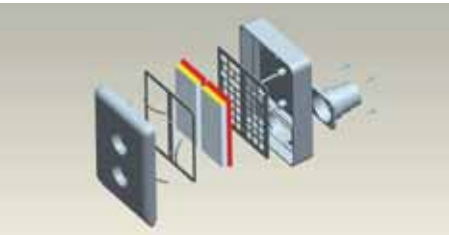
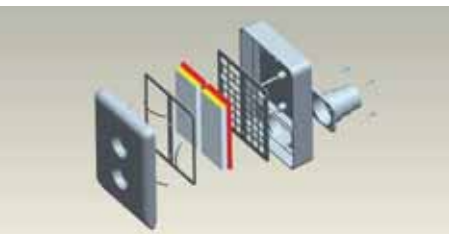





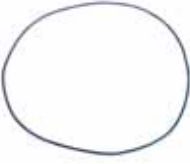





CG600

<p>22497457</p>  <ul style="list-style-type: none"> • Deckblech • Cover plate • Coiffe • Lamiera di copertura • Afdekkap 	<p>C22497457</p> <p>IC R-PTO L</p>	<p>22497465</p>  <ul style="list-style-type: none"> • Deckblech • Cover plate • Coiffe • Lamiera di copertura • Afdekkap 	<p>C22497465</p> <p>IC L-PTO R</p>
<p>22497432</p>  <ul style="list-style-type: none"> • Deckblech • Cover plate • Coiffe • Lamiera di copertura • Afdekkap 	<p>C22497432</p> <p>R-PTO L</p>	<p>22497440</p>  <ul style="list-style-type: none"> • Deckblech • Cover plate • Coiffe • Lamiera di copertura • Afdekkap 	<p>C22497440</p> <p>L-PTO R</p>
<p>83904197GHH</p>  <ul style="list-style-type: none"> • Sichtfenster • Sight glass • Voyant • Vetro • Kijkglas 	<p>83904197</p> <p>IC R-PTO L IC L-PTO R R-PTO L L-PTO R</p>		
<p>22497788</p>  <ul style="list-style-type: none"> • Gebläse-Einströmgehäuse • Cover for air cooler • Carter de protection ventilateur • Carcassa d'entrata soffiante • Beschermplaat voor de ventilator 	<p>C22497788</p> <p>IC R-PTO L</p>	<p>22497796</p>  <ul style="list-style-type: none"> • Gebläse-Einströmgehäuse • Cover for air-cooler • Capot de protection ventilateur • Carcassa d'entrata soffiante • Beschermplaat voor ventilator 	<p>C22497796</p> <p>IC L-PTO R</p>
<p>22497549</p>  <ul style="list-style-type: none"> • Frontblech • Front plate • Avant-coiffe • Lamiera di protezione • Frontplaat 	<p>C22497549</p> <p>R-PTO L</p>	<p>22497556</p>  <ul style="list-style-type: none"> • Frontblech • Front plate • Avant-coiffe • Lamiera di protezione • Frontplaat 	<p>C22497556</p> <p>L-PTO R</p>
<p>22497838</p>  <ul style="list-style-type: none"> • Luftleitblech • Baffle plate • Déflecteur d'air • Lamiera per tubo dell'aria • Luchtgeleidingsplaat 	<p>C22497838</p> <p>IC R-PTO L</p>	<p>22497853</p>  <ul style="list-style-type: none"> • Luftleitblech • Baffle plate • Déflecteur d'air • Lamiera per tubo dell'aria • Luchtgeleidingsplaat 	<p>C22497853</p> <p>IC L-PTO R</p>



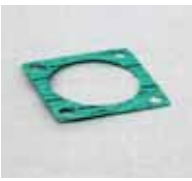



<p>22497580</p>  <ul style="list-style-type: none"> • Frontblechverlängerung • Front plate extension • Avant-coiffe prolongée • Lamiera di protezione prolungata • Frontplaat afstandshoude 	<p>C22497580</p> <p>R-PTO L</p>	<p>22497598</p>  <ul style="list-style-type: none"> • Frontblechverlängerung • Front plate extension • Avant-coiffe prolongée • Lamiera di protezione prolungata • Frontplaat afstandshoude 	<p>C22497598</p> <p>L-PTO R</p>
<p>22497820</p> 		<ul style="list-style-type: none"> • Halteplatte Riemenschutz • Holding plate V-belt protector • Support pour carter de protection pour les courroies • Controllo protezione cinghie trapezoidali • Steun voor V-snaarbeschermkap 	<p>C22497820</p> <p>Alle Typen All types Toutes var. Tutti versioni Allen typen</p>
<p>22623961</p>  <ul style="list-style-type: none"> • Halteplatte • Fastening plate • Fixation • Fissaggio • Steun 	<p>C22623961</p> <p>IC R-PTO L IC L-PTO R</p>		
<p>22497663</p>  <ul style="list-style-type: none"> • Riemenschutz • V-belt protector • Carter de protection pour les courroies • Protezione cinghie trapezoidali • V-riem beschermkap 	<p>C22497663</p> <p>IC R-PTO L R-PTO L</p>	<p>22497671</p>  <ul style="list-style-type: none"> • Riemenschutz • V-belt protector • Carter de protection pour les courroies • Protezione cinghie trapezoidali • V-snaar beschermkap 	<p>C22497671</p> <p>IC L-PTO R</p>
<p>83904261GHH</p>  <ul style="list-style-type: none"> • Riemenschutz ALU • V-belt protector, alum. • Carter de protection pour les courroies, alum. • Protezione cinghie trapezoidali, alum. • V-snaarbeschermkap, alum. 	<p>83904261</p> <p>Light R-PTO L</p>	<p>83904260GHH</p>  <ul style="list-style-type: none"> • Riemenschutz ALU • V-belt protector, alum. • Carter de protection pour les courroies • Protezione cinghie trapezoidali, alum. • V-snaarbeschermkap, alum. 	<p>83904260</p> <p>Light L-PTO R</p>

<p>22555809</p>  <ul style="list-style-type: none"> • Luftansaugfilter • Suction air filter • Filtre d'air • Filtro aspirazione aria • Aanzuigfilter 	<p>C22555809</p> <p>IC R-PTO L</p>	<p>22555791</p>  <ul style="list-style-type: none"> • Luftansaugfilter • Suction air filter • Filtre d'air • Filtro aspirazione aria • Aanzuigfilter 	<p>C22555791</p> <p>IC L-PTO R</p>
<p>22486898</p>  <ul style="list-style-type: none"> • Luftansaugfilter • Suction air filter • Filtre d'air • Filtro aspirazione aria • Aanzuigfilter 	<p>C22486898</p> <p>R-PTO L</p>	<p>22486872</p>  <ul style="list-style-type: none"> • Luftansaugfilter • Suction air filter • Filtre d'air • Filtro aspirazione aria • Aanzuigfilter 	<p>C22486872</p> <p>L-PTO R</p>
<p>23263718</p> 		<ul style="list-style-type: none"> • Luftansaugfilter für externe Ansaugung • Suction air filter for remote air intake • Filtre d'air • Filtro aspirazione aria • Aanzuigfilter 	<p>C23263718</p> <p>IC R-PTO L R-PTO L</p>
<p>23263726</p> 		<ul style="list-style-type: none"> • Luftansaugfilter für externe Ansaugung • Suction air filter for remote air intake • Filtre d'air • Filtro aspirazione aria • Aanzuigfilter 	<p>C23263726</p> <p>IC L-PTO R L-PTO R</p>
<p>83904840GHH</p> 		<ul style="list-style-type: none"> • Filterelement • Filter cartridge • Element filtrant • Cartucce per filtro • Filterelement 	<p>83904840</p> <p>IC R-PTO L IC L-PTO R R-PTO L L-PTO R</p>
<p>22486328</p>  <ul style="list-style-type: none"> • Einströmdeckel • Air filter cover • Couvercle d'admission • Coperchio d'ammissione • Luchtfilter deksel 	<p>C22486328</p> <p>IC R-PTO L IC L-PTO R R-PTO L L-PTO R</p>	<p>83904203GHH</p>  <ul style="list-style-type: none"> • Wechselspanrahmen • Filter mounting frame • Cadre de serrage • Telaio a tensione • Filterspanframe 	<p>83904203</p> <p>IC R-PTO L IC L-PTO R R-PTO L L-PTO R</p>









<p>22603021</p>  <ul style="list-style-type: none"> • O-Dichtring • O-ring for air filter • Joint torique pour filtre d'aspiration d'air • Anello di tenuta circolare • O-ring voor Aanzuigfilter 	<p>C22603021</p> <p>IC R-PTO L IC L-PTO R R-PTO L L-PTO R</p>	<p>22479505</p>  <ul style="list-style-type: none"> • Sterngriff • Star knob • Ecrou poigné étoile • Dado manopola a crociera • Ster schroefknop 	<p>C22479505</p> <p>IC R-PTO L IC L-PTO R R-PTO L L-PTO R</p>
<p>22486302</p>  <ul style="list-style-type: none"> • Distanzstück 110x110x85 • Spacer • Pièce d'écartement • Flangia distanziale • Afstandsstuk 	<p>C22486302</p> <p>IC R-PTO L IC L-PTO R</p>	<p>22571491</p>  <ul style="list-style-type: none"> • Distanzstück 110x110x14,5 • Spacer • Pièce d'écartement • Flangia distanziale • Afstandsstuk 	<p>C22571491</p> <p>R-PTO L L-PTO R</p>
<p>37600775GHH</p>  <ul style="list-style-type: none"> • Flachdichtung saugseitig 1,5mm dick DN80 • Flat gasket, suction side • Joint de bride côté aspiration • Guarnizione • Pakking 		<p>37600775</p> <p>Alle Typen All types Toutes var. Tutti versioni Allen typen</p>	
<p>23750805</p>  <ul style="list-style-type: none"> • Luftansaugfilter • Suction air filter • Filtre d'air • Filtro aspirazione aria • Aanzuigfilter 	<p>C23750805</p> <p>Light R-PTO L</p>	<p>23750813</p>  <ul style="list-style-type: none"> • Luftansaugfilter • Suction air filter • Filtre d'air • Filtro aspirazione aria • Aanzuigfilter 	<p>C23750813</p> <p>Light L-PTO R</p>
<p>22473185</p>  <ul style="list-style-type: none"> • Filterelement • Filter cartridge • Element filtrant • Gruppo cartucce • Filterelement 	<p>C22473185</p> <p>Light R-PTO L Light L-PTO R</p>	<p>22723079</p>  <ul style="list-style-type: none"> • Luftfilterdeckel • Air filter cover • Couvercle de filtre d'aspiration d'air • Coperchio filtro aspirazione aria • Luchtfilterdeksel 	<p>C22723079</p> <p>Light R-PTO L Light L-PTO R</p>
<p>83904235GHH</p>  <ul style="list-style-type: none"> • Filtereinsatz 310x230x30mm • Filter cartridge • Element filtrant • Cartucce per filtro • Filterelement 			<p>83904235</p> <p>Light R-PTO L Light L-PTO R</p>











<p>22995955</p> 	<p>C22995955</p> <ul style="list-style-type: none"> • Ansaugleitung-Kit ohne Zwischenstück • Suction pipe kit without adapter • Ligne d'aspiration kit sans raccord • Kit fissaggio tubo aspirazione senza raccordo • Aanzuigleidingkit zonder tussenstuk 	<p>C22995955</p> <p>Light R-PTO L Light L-PTO R</p>
<p>23101116</p>  <ul style="list-style-type: none"> • Flachdichtung DN86 • Flat gasket • Joint de bride • Guarnizione • Paking 	<p>C23101116</p> <p>Light R-PTO L Light L-PTO R</p>	
<p>22968911</p> 	<p>C22968911</p> <ul style="list-style-type: none"> • Luftansaugfilter Europiclon mit Regenkappe (12 m³/min.) • Suction air filter Europiclon with rain cap • Filtre d'aspiration d'air Europiclon avec chapeau contre la pluie • Filtro aspirazione aera Europiclon con coperchio • Aanzuigfilter Europiclon met regenkap 	<p>C22968911</p> <p>Optional</p>
<p>22968937</p> 	<p>C22968937</p> <ul style="list-style-type: none"> • Filterpatrone für Luftfilter 22968911 • Filter cartridge for air filter • Element filtrant pour filtre d'air • Cartucce per filtro aria • Filterelement voor luchtfilter 	<p>C22968937</p> <p>Optional</p>
<p>22968929</p>  <ul style="list-style-type: none"> • Halter für Luftfilter 22968911 • Holder for air filter • Cadre support pour filtre d'air • Manicotti per filtro aria • Luchtfiltersteunen voor luchtfilter 	<p>C22968929</p> <p>Optional</p>	
<p>24667131</p>  <ul style="list-style-type: none"> • Halter für Luftfilter 22968911 • Holder for air filter • Cadre support pour filtre d'air • Manicotti per filtro aria • Luchtfiltersteunen voor luchtfilter 	<p>C24667131</p> <p>Optional</p>	









<p>24059263</p>  <ul style="list-style-type: none"> • Luftfilter PSD 9–13m³/min (90°) • Air filter PSD 9–13m³/min (90°) 	<p>C24059263</p> <p>Optional</p>	<p>24865073</p>  <ul style="list-style-type: none"> • Filterpatrone für PSD-Serie (9-13m³/min) • Filter cartridge for PSD series • Element filtrant pour PSD • Cartucce per filtro aria PSD • Filterelement voor PSD 	<p>C24865073</p> <p>Optional</p>
<p>24667370</p>  <ul style="list-style-type: none"> • Logoblech für 24059263 • Logo sign for 24059263 	<p>C24667370</p> <p>Optional</p>	<p>24667131</p>  <ul style="list-style-type: none"> • Halter für Luftfilter 24059263 • Holder for air filter • Cadre support pour filtre d'air • Manicotti per filtro aria • Luchtfiltersteunen voor luchtfilter 	<p>C24667131</p> <p>Optional</p>
<p>47533863001</p>  <ul style="list-style-type: none"> • Wartungsanzeiger • Maintenance indicator • Indicateur d'entretien • Indicatore per manutenzione • Onderhoudsindicator 	<p>N/A</p> <p>Optional</p>		
<p>22749543</p>  <ul style="list-style-type: none"> • Schlauchanschlussflansch DN100 • Hose connection • Utricule raccordement • Guarnizione per tubo • Aansluitflens voor slang 	<p>C22749543</p> <p>Light R-PTO L Light L-PTO R</p>	<p>47533560001</p>  <ul style="list-style-type: none"> • Schlauchanschlussflansch 90° • Hose connection 90° • Utricule raccordement • Guarnizione per tubo • Aansluitflens voor slang 	<p>N/A</p> <p>Light R-PTO L Light L-PTO R</p>
<p>23280233</p>  <ul style="list-style-type: none"> • Spiralschlauch DN100 • Flexible hose • Tuyaux flexible • Tubo flessibile • Spiraalslang 	<p>C23280233</p> <p>Light R-PTO L Light L-PTO R</p>	<p>22682132</p>  <ul style="list-style-type: none"> • Schlauchschelle 90–110 • Hose clip • Collier de serrage • Cravatta fermatubi • Slangeklem 	<p>C22682132</p> <p>Light R-PTO L Light L-PTO R</p>

<p>22486849</p>  <ul style="list-style-type: none"> • Luftansaugdämpfer SD-84 • Air suction silencer • Silencieux aspiration d'air • Ammortizzatore aspirazione aria • Aanzuigdemper 	<p>C22486849</p> <p>IC R-PTO L R-PTO L</p>	<p>22486831</p>  <ul style="list-style-type: none"> • Luftansaugdämpfer SD-84 • Air suction silencer • Silencieux aspiration d'air • Ammortizzatore aspirazione aria • Aanzuigdemper 	<p>C22486831</p> <p>IC L-PTO R L-PTO R</p>
<p>22482152</p> 	<ul style="list-style-type: none"> • Deckeldichtung für Luftansaugdämpfer SD-84 • Cover gasket for air suction silencer • Joint de couvercle pour silencieux aspiration d'air • Guarnizione coperchio per aspirazione aria • Dekselpakking voor aanzuigdemper 	<p>C22482152</p> <p>IC R-PTO L IC L-PTO R R-PTO L L-PTO R</p>	
<p>37600775GHH</p> 	<ul style="list-style-type: none"> • Flachdichtung saugseitig 1,5mm dick DN80 • Flat gasket, suction side • Joint de bride côté aspiration • Guarnizione • Pakking 	<p>37600775</p> <p>Alle Typen All types Toutes var. Tutti versioni Allen typen</p>	
<p>22486526</p> 	<ul style="list-style-type: none"> • Druckschalldämpfer DS84, mit Schlauchstutzen inkl. Rückschlagventil • Discharge silencer DS84, with hose connection incl. non-return valve • Silencieux de refoulement DS84, avec raccord de tuyau et clapet anti-retour • Silenziatore pressione DS84, con tubo di collegamento e valvola di non-ritorno • Persdemper voor DS84 incl. slangaansluiting en terugslagklep 	<p>C22486526</p> <p>IC R-PTO L IC L-PTO R</p>	
<p>22486674</p> 	<ul style="list-style-type: none"> • Druckschalldämpfer DS84, G2.5" inkl. Rückschlagventil • Discharge silencer DS84, G2.5" incl. non-return valve • Silencieux de refoulement DS84, G2.5" avec clapet anti-retour • Silenziatore pressione DS84, G2.5" compr. valvola di non-ritorno • Persdemper voor DS84 G2.5" incl. terugslagklep 	<p>C22486674</p> <p>R-PTO L L-PTO R</p>	
<p>22486112</p> 	<ul style="list-style-type: none"> • Ausströmkopf-Verlängerung • Discharge silencer head extension 	<p>C22486112</p> <p>IC R-PTO L IC L-PTO R R-PTO L L-PTO R</p>	





<p>83904193GHH</p> 	<ul style="list-style-type: none"> • Flanschdichtung druckseitig für Verlängerung • Flange gasket discharge side for extension • Joint de bride côté refoulement • Guarnizione per prolungamento • Flenspakking voor verlenging 	<p>83904193</p> <p>IC R-PTO L IC L-PTO R R-PTO L L-PTO R</p>	
<p>24224586</p> 	<ul style="list-style-type: none"> • Ausströmkopf DS84/87 mit Schlauchstutzen • Discharge silencer head DS84/87 with hose connection 	<p>C24224586</p> <p>IC R-PTO L IC L-PTO R</p>	
<p>24224594</p>  <ul style="list-style-type: none"> • Ausströmkopf DS84/87 mit 2,5" AG • Discharge silencer head DS84/87 with 2.5" male thread 	<p>C24224594</p> <p>R-PTO L L-PTO R</p>	<p>22486443</p>  <ul style="list-style-type: none"> • Flansch Luftaustritt mit 2,5" AG • Flange for air outlet with 2.5" male thread • Bride pour sortie d'air • Guarnizione per uscita aria • Flens uitlaatlicht 	<p>C22486443</p> <p>Light R-PTO L Light L-PTO R</p>
<p>22603047</p> 	<ul style="list-style-type: none"> • Druckschalldämpfer DSD700 inkl. Rückschlagventil • Discharge silencer incl. non-return valve • Silencieux de refoulement avec clapet anti-retour • Silenziatore pressione compr. valvola di non-ritorno • Persdemper inclusief terugslagklep 	<p>C22603047</p> <p>Light R-PTO L Light L-PTO R</p>	
<p>24478976</p>  <ul style="list-style-type: none"> • Deckblech für Druckschalldämpfer DSD700 • Cover plate for discharge silencer DSD700 	<p>C24478976</p> <p>Light R-PTO L Light L-PTO R</p>	<p>24519407</p>  <ul style="list-style-type: none"> • Deckblech-Kit für Druckschalldämpfer DSD700 • Cover plate kit for discharge silencer DSD700 	<p>C24519407</p> <p>Light R-PTO L Light L-PTO R</p>
<p>12792GHH</p>  <ul style="list-style-type: none"> • Druckschalldämpfer-Kopf • Discharge silencer head • Tête de silencieux de refoulement • Persdemperkop 	<p>12792</p> <p>Light R-PTO L Light L-PTO R</p>	<p>22485031</p>  <ul style="list-style-type: none"> • Blindstopfen 2,5" • Blind plug • Plot de remplissage • Tappo • Blindplug 	<p>C22485031</p> <p>IC R-PTO L IC L-PTO R</p>





<p>14824GHH</p> 	<ul style="list-style-type: none"> • Dichtung weiß für 22485031 • O-Ring white for 22485031 	<p>14824</p> <p>IC R-PTO L IC L-PTO R</p>		
<p>22480560</p> 	<ul style="list-style-type: none"> • Rückschlagventil RV-50.1 • Non-return valve • Soupape anti-retour • Valvola di non-ritorno • Terugslagklep 	<p>C22480560</p> <p>Alle Typen All types Toutes var. Tutti versioni Allen typen</p>	<p>22554794</p> 	<p>C22554794</p> <ul style="list-style-type: none"> • Dichtung DN50 für RV-50.1 (Einsatzmenge: 2 p. Ventil) • Gasket DN50 for RV-50.1 (Req. quantity: 2 per valve) • Joint d'étanchéité du soupape • Guarnizione • Afdichtingskit <p>Alle Typen All types Toutes var. Tutti versioni Allen typen</p>
<p>24064453</p> 	<ul style="list-style-type: none"> • Druckschalldämpfer DSD600 „NSG“ inkl. Rückschlagventil • Discharge silencer DSD600 „NSG“ incl. non-return valve 	<p>C24064453</p> <p>Light R-PTO L Light L-PTO R</p>	<p>24341166</p> 	<p>C24341166</p> <ul style="list-style-type: none"> • Deckblech für Druckschalldämpfer DSD600 „NSG“ • Cover plate for discharge silencer DSD600 „NSG“ <p>Light R-PTO L Light L-PTO R</p>
<p>24617060</p> 	<ul style="list-style-type: none"> • Druckschalldämpfer DSD600 „NSG“ Nachrüstkit • Discharge silencer DSD600 „NSG“ retrofit kit 	<p>C24617060</p> <p>Light R-PTO L Light L-PTO R</p>		
<p>83901289GHH</p> 	<ul style="list-style-type: none"> • Sicherheitsventil G 1 1/2", 2,6 bar • Safety relief valve • Soupape de sûreté • Valvola di sicurezza • Overdrukventiel 	<p>83901289</p> <p>Alle Typen All types Toutes var. Tutti versioni Allen typen</p>		
<p>37600776GHH</p> 	<ul style="list-style-type: none"> • Flachdichtung druckseitig 2,0mm dick DN70 • Flat gasket, discharge side • Joint de bride côté refoulement • Guarnizione • Pakking 	<p>37600776</p> <p>Alle Typen All types Toutes var. Tutti versioni Allen typen</p>		







<p>22515134</p>  <ul style="list-style-type: none"> • Druckluftkühler • Discharge air cooler • Réfrigérant d'air de refoulement • Ventilatore forzato • Drukluftkoeler 	<p>C22515134</p> <p>IC R-PTO L</p>	<p>22515126</p>  <ul style="list-style-type: none"> • Druckluftkühler • Discharge air cooler • Réfrigérant d'air de refoulement • Ventilatore forzato • Drukluftkoeler 	<p>C22515126</p> <p>IC L-PTO R</p>
<p>22477988</p>  <ul style="list-style-type: none"> • Elektrolüfter 24 Volt • Electric fan • Ventilateur électronique • Ventilatore per refrigeratore aria • Ventilator 	<p>C22477988</p> <p>IC R-PTO L IC L-PTO R</p>	<p>83904184GHH</p>  <ul style="list-style-type: none"> • Schlauchschelle DN60 • Hose clip • Collier de serrage • Cravatta fermatubi • Slangeklem 	<p>83904184</p> <p>IC R-PTO L IC L-PTO R</p>
<p>22622732</p>  <ul style="list-style-type: none"> • Verbindungsschlauch DN60x9x160 oben • Flexible hose, top • Tuyaux de raccord • Raccordo a tubo flessibile • Verbindingslang 	<p>C22622732</p> <p>IC R-PTO L IC L-PTO R</p>	<p>22622724</p>  <ul style="list-style-type: none"> • Verbindungsschlauch DN60x9x220 unten • Flexible hose, bottom • Tuyaux de raccord • Raccordo a tubo flessibile • Verbindingslang 	<p>C22622724</p> <p>IC R-PTO L IC L-PTO R</p>
<p>22486427</p>  <ul style="list-style-type: none"> • Zwischendruckleitung • Interstage pressure pipe • Conduite rigide de refoulement intermédiaire • Tubazione di mandata intermedia • Verbindingsdrukleiding 	<p>C22486427</p> <p>IC R-PTO L IC L-PTO R</p>	<p>22598536</p>  <ul style="list-style-type: none"> • Distanzstück 110x110x25 • Spacer • Pièce d'écartement • Flangia distanziale • Afstandsstuk 	<p>C22598536</p> <p>IC R-PTO L IC L-PTO R</p>
<p>22486419</p> 	<p>C22486419</p> <ul style="list-style-type: none"> • Verlängerung 90° für Zwischendruckleitung • Extension 90° for interstage pressure pipe • Allonge 90° pour conduite rigide de refoulement intermédiaire • Prolungamento 90° per tubazione di mandata intermedia • Verlengstuk 90° voor verbindingsdrukleiding 	<p>C22486419</p> <p>IC R-PTO L IC L-PTO R</p>	
<p>22659619</p> 	<p>C22659619</p> <ul style="list-style-type: none"> • Verlängerung für Zwischendruckleitung 2,5", gerade • Extension for interstage pressure pipe 2.5", straight • Allonge conduite rigide droite de refoulement intermédiaire 2,5" • Prolungamento per tubazione dritta di mandata intermedia 2,5" • Verlengstuk voor verbindingsdrukleiding, recht 2,5" 	<p>C22659619</p> <p>IC R-PTO L IC L-PTO R</p>	









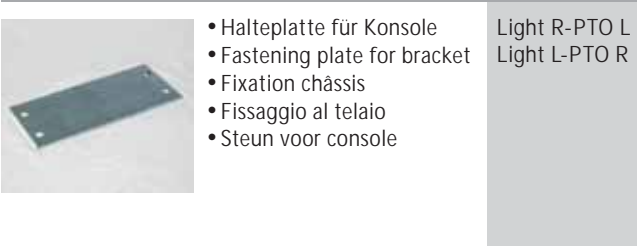

<p>2336610</p> 	<p>• Steuerkontrollgerät • Control unit • Boîtier de contrôle/commande • Dispositivo controllo di comando • Control unit</p>	<p>C2336610 IC R-PTO L IC L-PTO R</p>	
<p>2336625</p>  <p>• Manometer 0–3–16 bar • Pressure gauge • Manomètre • Manometro • Manometer</p>	<p>C2336625 IC R-PTO L IC L-PTO R R-PTO L L-PTO R</p>	<p>22569248</p>  <p>• Reduzier-Stück für Manometer • Reducer for manometer</p>	<p>C22569248 IC R-PTO L IC L-PTO R R-PTO L L-PTO R</p>
<p>83903302GHH</p>  <p>• Wartungsanzeiger • Maintenance indicator • Indicateur d'entretien • Indicatore per manutenzione • Onderhoudsindicator</p>	<p>83903302 Alle Typen All types Toutes var. Tutti versioni Allen typen</p>	<p>22530190</p>  <p>• Haltebügel Wartungsan- zeige • Holding bow maintenance indicator</p>	<p>C22530190 R-PTO L L-PTO R</p>
<p>23371511</p>  <p>• Schlauch DN2x190 • Hose • Tuyaux • Tubo • Slang</p>	<p>C23371511 IC R-PTO L IC L-PTO R</p>	<p>23928658</p>  <p>• Regelelektronik komplett YG 39-E • Electronic control • Ens. électronique de régulation • Sistema elettronico regolazione • Electronische regeleenheid</p>	<p>C23371511 IC R-PTO L IC L-PTO R</p>
<p>22571830</p> 	<p>• Temperaturanzeiger für Steuerkontrollgerät • Temperature indicator for control unit • Indicateur de température pour boîtier de contrôle • Indicatore di temperatura • Temperatuur indicator voor control unit</p>	<p>C22571830 IC R-PTO L IC L-PTO R</p>	
<p>24211914</p> 	<p>• Hauptschalter zweistufig für SKG • Main switch double-stage for control unit</p>	<p>C24211914 IC R-PTO L IC L-PTO R</p>	

<p>22571855</p>  <ul style="list-style-type: none"> • Wahlschalter Dauerbetrieb • Selector switch continuous duty • Interrupteur sélecteur service continu • Interruttore • Keuzeschakelaar continuebedrijf 	<p>C22571855</p> <p>IC R-PTO L IC L-PTO R</p>	<p>22571863</p>  <ul style="list-style-type: none"> • Drehzahlsteller Potentiometer • Speed regulator • Régulateur de vitesse • Regolatore numero di giri • Potentiometer 	<p>C22571863</p> <p>IC R-PTO L IC L-PTO R</p>
<p>83904429GHH</p>  <ul style="list-style-type: none"> • Öldruckschalter 1polig alte Ausführung • Oil pressure switch 1-pole old design 	<p>83904429</p> <p>IC R-PTO L IC L-PTO R</p>	<p>24626954</p>  <ul style="list-style-type: none"> • Kontrollleuchtdiode IP67 • Control diode IP67 • Diode de contrôle IP67 • Diode IP67 • Controlelicht diode IP67 	<p>C24626954</p> <p>IC R-PTO L IC L-PTO R</p>
<p>22940506</p>  <ul style="list-style-type: none"> • Fernthermometer-Geber elektr. 2-polig • Thermometer 2-pole • Capteur électr. bipolaire de téléthermomètre • Indicatore di temperatura 2-poli • Thermometer 2-polig 	<p>C22940506</p> <p>IC R-PTO L IC L-PTO R</p>	<p>22940613</p>  <ul style="list-style-type: none"> • Umrüstkit Fernthermometer • Changeover kit remote thermometer • Kit de modification pour téléthermomètre • Kit modificazione indicatore di temperatura • Modificatiekit Thermometer 	<p>C22940613</p> <p>IC R-PTO L IC L-PTO R</p>
<p>14759GHH</p>  <ul style="list-style-type: none"> • Hochstrom-Sicherungshalter • Fuse holder • Porte-fusible • Portafusibile • Zekeringhouder 	<p>14759</p> <p>IC R-PTO L IC L-PTO R</p>	<p>14760GHH</p>  <ul style="list-style-type: none"> • Sicherungsstreifen 30 Amp. • Safety bar • Bande de protection • Striscetta di controllo • Beveiligingsstrips 	<p>14760</p> <p>IC R-PTO L IC L-PTO R</p>
<p>23094048</p> 	<p>C23094048</p> <ul style="list-style-type: none"> • Steckverbinder DUCON komplett, wasserdicht • DUCON connector complete, waterproof • Connecteur DUCON complet, étanche • Giunto a spine DUCON compl., impermeabile all'acqua • Stekkerverbinding DUCON compleet, waterdicht 	<p>C23094048</p> <p>IC R-PTO L IC L-PTO R</p>	
<p>22532162</p> 	<p>C22532162</p> <ul style="list-style-type: none"> • Schlauchleitung Öldruckmanometer 500mm • Flexible hose oil pressure gauge • Tuyaux pour manomètre d'huile • Tubo flessibile per manometro olio • Flexibele leiding voor oliedrukmeter 	<p>C22532162</p> <p>IC R-PTO L IC L-PTO R</p>	

22532154 	<ul style="list-style-type: none">• Schlauchleitung Öldruckmanometer 360mm• Flexible hose oil pressure gauge• Tuyaux pour manomètre d'huile• Tubo flessibile per manometro olio• Flexibele leiding voor oliedrukmeter	C22532154 R-PTO L L-PTO R
23449085 	<ul style="list-style-type: none">• Schlauch DN2x320• Hose• Tuyaux• Tubo• Slang	C23449085 IC R-PTO L IC L-PTO R
22532170 	<ul style="list-style-type: none">• Schlauchleitung Wartungsanzeiger 550mm• Flexible hose line for maintenance indicator• Tuyaux pour indicateur d'entretien• Tubo flessibile per indicatore• Flexibele leiding voor onderhouds indicatop	C22532170 R-PTO L L-PTO R
22787980  <ul style="list-style-type: none">• Rohrfedermanometer für Öldruck 0–4 bar• Oil pressure gauge• Manomètre de pression d'huile• Manometro pressione olio• Oliedrukmeter	C22787980 Light R-PTO L Light L-PTO R	23262140  <ul style="list-style-type: none">• Verschraubung für Ölmanometer (Winkel)• Fitting for oil gauge• Raccord à vis pour manomètre à huile• Raccordo a vite per manometro d'olio• Fitting voor de oliedrukmeter

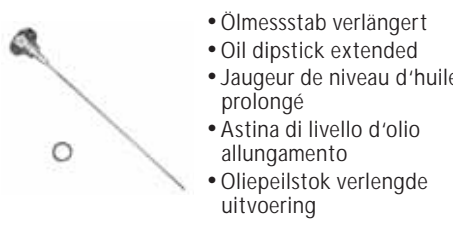
<p>22512545-ATO*</p>  <ul style="list-style-type: none"> • Montagekonsole kompl. mit Antrieb • Bracket complete with drive • Console de montage avec commande • Supporto di montaggio con trasmissione • Montageconsole compleet met aandrijving 	<p>C22512545</p> <p>IC R-PTO L R-PTO L</p>	<p>22512529-ATO*</p>  <ul style="list-style-type: none"> • Montagekonsole kompl. mit Antrieb • Bracket complete with drive • Console de montage avec commande • Supporto di montaggio con trasmissione • Montageconsole compleet met aandrijving 	<p>C22512529</p> <p>IC L-PTO R L-PTO R</p>
<p>22512602-ATO*</p>  <ul style="list-style-type: none"> • Montagekonsole kompl. mit Antrieb • Bracket complete with drive • Console de montage avec commande • Supporto di montaggio con trasmissione • Montageconsole compleet met aandrijving 	<p>C22512602</p> <p>Light R-PTO L</p>	<p>22512594-ATO*</p>  <ul style="list-style-type: none"> • Montagekonsole kompl. mit Antrieb • Bracket complete with drive • Console de montage avec commande • Supporto di montaggio con trasmissione • Montageconsole compleet met aandrijving 	<p>C22512594</p> <p>Light L-PTO R</p>
<p>22497291</p>  <ul style="list-style-type: none"> • Montagekonsole ohne Antrieb • Bracket without drive • Console de montage sans commande • Supporto di montaggio senza trasmissione • Montageconsole zonder aandrijving 	<p>C22497291</p> <p>IC R-PTO L R-PTO L Light R-PTO L</p>	<p>22497283</p>  <ul style="list-style-type: none"> • Montagekonsole ohne Antrieb • Bracket without drive • Console de montage sans commande • Supporto di montaggio senza trasmissione • Montageconsole zonder aandrijving 	<p>C22497283</p> <p>IC L-PTO R L-PTO R Light L-PTO R</p>
<p>22793129</p>  <ul style="list-style-type: none"> • Rahmenbefestigung für Konsole • Frame fastening for bracket • Fixation châssis pour console de montage • Fissaggio al telaio • Framebevestiging voor console 	<p>C22793129</p> <p>Alle Typen All types Toutes var. Tutti versioni Allen typen</p>	<p>23460066</p>  <ul style="list-style-type: none"> • Ausgleichskeil MAN TGX/TGS Radstand 3600mm • Angle shim 	<p>C23460066</p> <p>Alle Typen All types Toutes var. Tutti versioni Allen typen</p>
<p>49005333</p>  <ul style="list-style-type: none"> • Rahmenbefestigung für MAN, Radstand 3600 mm • Frame fastening for bracket for MAN, wheel base 3600 mm 	<p>N/A</p> <p>Alle Typen All types Toutes var. Tutti versioni Allen typen</p>	<p>24487282</p>  <ul style="list-style-type: none"> • Rahmenbefestigung für Konsole, verstärkt für MAN TGA, Radstand 3900 mm • Frame fastening for bracket, strengthened for MAN TGA, wheel base 3900 mm 	<p>C24487282</p> <p>R-PTO L</p>
<p>24087348</p>  <ul style="list-style-type: none"> • Rahmenbefestigung verbreitert für Actros 4 • Frame fastening for bracket broadened for Actros 4 	<p>C24087348</p> <p>Alle Typen All types Toutes var. Tutti versioni Allen typen</p>	<p>23931611</p>  <ul style="list-style-type: none"> • Schrauben-Satz für Rahmenbefestigung • Screw-kit for frame fastening for bracket • Visser pour fixation de cadre • Viti per telaio di fissaggio • Schroeven voor frame monteren 	<p>C23931611</p> <p>Alle Typen All types Toutes var. Tutti versioni Allen typen</p>

<p>22486922</p> 	<p>C22486922</p> <ul style="list-style-type: none"> • Lagerbock/Antriebkonsole inkl. Gelenkwellenflansch und Spannvorrichtung • Bearing pedestal incl. drive shaft flange and mounting clamps • Support de palier/console entrainement avec joint onduler de bride et dispositif de serrage • Cavalletto del cuscinetto/supporto motore con flangia per giunto e fissaggio • Lagerblok met aandrijving inkl. aandrijfflens en spaninrichting 	<p>C22486922</p> <p>IC R-PTO L R-PTO L Light R-PTO L</p>
<p>22488266</p> 	<p>C22488266</p> <ul style="list-style-type: none"> • Lagerbock/Antriebkonsole inkl. Gelenkwellenflansch und Spannvorrichtung • Bearing pedestal incl. drive shaft flange and mounting clamps • Support de palier/console entrainement avec joint onduler de bride et dispositif de serrage • Cavalletto del cuscinetto/supporto motore con flangia per giunto e fissaggio • Lagerblok met aandrijving inkl. aandrijfflens en spaninrichting 	<p>C22488266</p> <p>IC L-PTO R L-PTO R Light L-PTO R</p>
<p>22513006</p> 	<p>C22513006</p> <ul style="list-style-type: none"> • Gelenkwellenflansch, Rechtsgewinde • Drive shaft flange, right-hand thread • Joint onduler de bride, filet à droite • Flangia per giunto, filettatura a destra • Aandrijfflens, rechtse schroefdraad 	<p>C22513006</p> <p>IC R-PTO L R-PTO L Light R-PTO L</p>
<p>22512990</p> 	<p>C22512990</p> <ul style="list-style-type: none"> • Gelenkwellenflansch, Linksgewinde • Drive shaft flange, left-hand thread • Joint onduler de bride, filet à gauche • Flangia per giunto, filettatura a sinistra • Aandrijfflens, linkse schroefdraad 	<p>C22512990</p> <p>IC L-PTO R L-PTO R Light L-PTO R</p>
<p>22573216</p> 	<p>C22573216</p> <ul style="list-style-type: none"> • Spannvorrichtung für Keilriemenantrieb • Mounting clamps for V-belt drive • Dispositif de serrage pour courroie trapézoidale • Fissaggio per gruppo cinghie trapezoidali • Spaninrichting voor V-snaar aandrijving 	<p>C22573216</p> <p>Alle Typen All types Toutes var. Tutti versioni Allen typen</p>
<p>22497309</p>  <ul style="list-style-type: none"> • Halteplatte für Kühler • Fastening plate for cooler • Fixation châssis • Fissaggio al telaio • Steun voor koeler 	<p>C22497309</p> <p>IC R-PTO L IC L-PTO R R-PTO L L-PTO R</p>	<p>22497317</p>  <ul style="list-style-type: none"> • Halteplatte für Konsole • Fastening plate for bracket • Fixation châssis • Fissaggio al telaio • Steun voor console

<p>22480701</p> 	<p>C22480701</p> <ul style="list-style-type: none"> • Festkupplung Storz B 2,5" IG • Storz B coupling 2.5" female thread 	<p>C22480701</p> <p>Alle Typen All types Toutes var. Tutti versioni Allen typen</p>
<p>22480693</p> 	<p>C22480693</p> <ul style="list-style-type: none"> • Blindeckel mit Kette Storz B • Blind cap with chain Storz B • Couvercle aveugle avec chaîne Storz B • Coperchio con catena Storz B • Blindkap met ketting Storz B 	<p>C22480693</p> <p>Alle Typen All types Toutes var. Tutti versioni Allen typen</p>
<p>22952337</p> 	<p>C22952337</p> <ul style="list-style-type: none"> • Festkupplung LM franz. Gr. 80 ohne Arretierung 2,5" IG • Fixed coupling LM French size 80 w/o catch 2.5" female thread <p>Alle Typen All types Toutes var. Tutti versioni Allen typen</p>	<p>22914147</p>  <ul style="list-style-type: none"> • Festkupplung, Blindeckel LM franz. Gr. 80 • Blind cap LM French size 80 • Couvercle aveugle LM dim. française 80 • Coperchio LM francese dim. 80 • Koppeling met blindkap Frans maat 80 <p>Alle Typen All types Toutes var. Tutti versioni Allen typen</p>
<p>13674GHH</p> 	<p>13674</p> <ul style="list-style-type: none"> • Kurvenstück TW 518 R 2,5" IG • Male tank wagon coupling, TW 518 R 2,5" IG <p>Light R-PTO L Light L-PTO R</p>	<p>11663GHH</p>  <ul style="list-style-type: none"> • Blindeckel 3" TW 506 • Blind cap 3" TW 506 <p>Light R-PTO L Light L-PTO R</p>
<p>83901298GHH</p> 	<p>83901298</p> <ul style="list-style-type: none"> • Ölmesstab verlängert • Oil dipstick extended • Jaugeur de niveau d'huile prolongé • Astina di livello d'olio allungamento • Oliepeilstok verlengde uitvoering <p>IC R-PTO L IC L-PTO R R-PTO L L-PTO R</p>	<p>83903276GHH</p>  <ul style="list-style-type: none"> • Dichtring für Ölmesstab • Sealing ring for oil dipstick <p>IC R-PTO L IC L-PTO R R-PTO L L-PTO R</p>
<p>22486484</p> 	<p>C22486484</p> <ul style="list-style-type: none"> • Rohrverlängerung • Pipe extension <p>IC R-PTO L IC L-PTO R R-PTO L L-PTO R</p>	<p>95433000GHH</p>  <ul style="list-style-type: none"> • Ölansaugsieb • Oil intake filter • Filtre d'huile admettre • Filtro d'olio • Olieaanzuigfilter <p>CG80R</p>











A photograph showing a white truck cab on the right and a silver engine component on the left. In the background is a building with a large white sign that reads 'GHH RAND' in red letters. The sky is blue with some clouds. The bottom of the image has a red curved overlay.



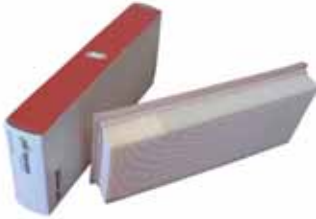

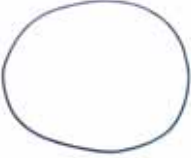



GHH RAND







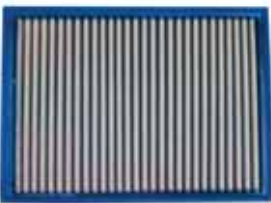

CS700

<p>22497499</p>  <ul style="list-style-type: none"> • Deckblech • Cover plate • Coiffe • Lamiera di copertura • Afdekkap 	<p>C22497499</p> <p>IC R-PTO L</p>	<p>22497507</p>  <ul style="list-style-type: none"> • Deckblech • Cover plate • Coiffe • Lamiera di copertura • Afdekkap 	<p>C22497507</p> <p>IC L-PTO R</p>
<p>22497473</p>  <ul style="list-style-type: none"> • Deckblech • Cover plate • Coiffe • Lamiera di copertura • Afdekkap 	<p>C22497473</p> <p>R-PTO L</p>	<p>22497481</p>  <ul style="list-style-type: none"> • Deckblech • Cover plate • Coiffe • Lamiera di copertura • Afdekkap 	<p>C22497481</p> <p>L-PTO R</p>
<p>83904197GHH</p>  <ul style="list-style-type: none"> • Sichtfenster • Sight glass • Voyant • Vetro • Kijkglas 	<p>83904197</p> <p>IC R-PTO L IC L-PTO R R-PTO L L-PTO R</p>	<p>22497804</p>  <ul style="list-style-type: none"> • Gebläse-Einströmgehäuse • Cover for air-cooler • Capot de protection ventilateur • Carcassa d'entrata soffiante • Beschermplaat voor ventilator 	<p>C22497804</p> <p>IC R-PTO L IC L-PTO R</p>
<p>22497564</p>  <ul style="list-style-type: none"> • Frontblech • Front plate • Avant-coiffe • Lamiera di protezione • Frontplaat 	<p>C22497564</p> <p>R-PTO L</p>	<p>22497572</p>  <ul style="list-style-type: none"> • Frontblech • Front plate • Avant-coiffe • Lamiera di protezione • Frontplaat 	<p>C22497572</p> <p>L-PTO R</p>
<p>22497861</p>  <ul style="list-style-type: none"> • Luftleitblech • Baffle plate • Déflecteur d'air • Lamiera per tubo dell'aria • Luchtgeleidingsplaat 	<p>C22497861</p> <p>IC R-PTO L</p>	<p>22497879</p>  <ul style="list-style-type: none"> • Luftleitblech • Baffle plate • Déflecteur d'air • Lamiera per tubo dell'aria • Luchtgeleidingsplaat 	<p>C22497879</p> <p>IC L-PTO R</p>
<p>22497606</p>  <ul style="list-style-type: none"> • Frontblechverlängerung • Front plate extension • Avant-coiffe prolongée • Lamiera di protezione prolungata • Frontplaat afstandshoude 	<p>C22497606</p> <p>R-PTO L</p>	<p>22497614</p>  <ul style="list-style-type: none"> • Frontblechverlängerung • Front plate extension • Avant-coiffe prolongée • Lamiera di protezione prolungata • Frontplaat afstandshoude 	<p>C22497614</p> <p>L-PTO R</p>

<p>23925175</p> 	<p>• Luftleitblech Erweiterungs-Kit • Air baffle plate extension-kit</p>	<p>C22497879 IC R-PTO L</p>	
<p>23925183</p> 	<p>• Luftleitblech Erweiterungs-Kit • Air baffle plate extension-kit</p>	<p>C23925183 IC L-PTO R</p>	
<p>22623920</p>  <p>• Winkelblech • Angle plate</p>	<p>C22623920 IC R-PTO L</p>	<p>22623938</p>  <p>• Winkelblech • Angle plate</p>	<p>C22623938 IC L-PTO R</p>
<p>22497820</p>  <p>• Halteplatte Riemenschutz • Holding plate V-belt protector • Support pour carter de protection pour les courroies • Controllo protezione cinghie trapezoidali • Steun voor V-snaarbeschermkap</p>	<p>C22497820 IC R-PTO L IC L-PTO R R-PTO L L-PTO R</p>	<p>22623961</p>  <p>• Halteplatte • Fastening plate • Fixation • Fissaggio • Steun</p>	<p>C22623961 IC R-PTO L IC L-PTO R</p>
<p>22497689</p>  <p>• Riemenschutz • V-belt protector • Carter de protection pour les courroies • Protezione cinghie trapezoidali • V-snaar beschermkap</p>	<p>C22497689 IC R-PTO L R-PTO L</p>	<p>22497697</p>  <p>• Riemenschutz • V-belt protector • Carter de protection pour les courroies • Protezione cinghie trapezoidali • V-snaar beschermkap</p>	<p>C22497697 IC L-PTO R L-PTO R</p>
<p>83904278GHH</p>  <p>• Riemenschutz ALU • V-belt protector, alum. • Carter de protection pour les courroies • Protezione cinghie trapezoidali, alum. • V-snaarbeschermkap, alum.</p>	<p>83904278 Light R-PTO L</p>	<p>83904277GHH</p>  <p>• Riemenschutz ALU • V-belt protector, alum. • Carter de protection pour les courroies • Protezione cinghie trapezoidali, alum. • V-snaarbeschermkap, alum.</p>	<p>83904277 Light L-PTO R</p>







<p>22555833</p>  <ul style="list-style-type: none"> • Luftansaugfilter • Suction air filter • Filtre d'air • Filtro aspirazione aria • Aanzuigfilter 	<p>C22555833</p> <p>IC R-PTO L</p>	<p>22555817</p>  <ul style="list-style-type: none"> • Luftansaugfilter • Suction air filter • Filtre d'air • Filtro aspirazione aria • Aanzuigfilter 	<p>C22555817</p> <p>IC L-PTO R</p>
<p>22486914</p>  <ul style="list-style-type: none"> • Luftansaugfilter • Suction air filter • Filtre d'air • Filtro aspirazione aria • Aanzuigfilter 	<p>C22486914</p> <p>R-PTO L</p>	<p>22486906</p>  <ul style="list-style-type: none"> • Luftansaugfilter • Suction air filter • Filtre d'air • Filtro aspirazione aria • Aanzuigfilter 	<p>C22486906</p> <p>L-PTO R</p>
<p>83904840GHH</p>  <ul style="list-style-type: none"> • Filterelement • Filter cartridge • Element fi ltrant • Cartucce per fi ltro • Filterelement 		<p>83904840</p> <p>IC R-PTO L IC L-PTO R R-PTO L L-PTO R</p>	
<p>22486336</p>  <ul style="list-style-type: none"> • Einströmdeckel • Air filter cover • Couvercle d'admission • Coperchio d'ammissione • Luchtfiler deksel 	<p>C22486336</p> <p>IC R-PTO L IC L-PTO R R-PTO L L-PTO R</p>	<p>83904374GHH</p>  <ul style="list-style-type: none"> • Wechselfspanrahmen • Filter mounting frame • Cadre de serrage • Telaio a tensione • Filterspanframe 	<p>83904374</p> <p>IC R-PTO L IC L-PTO R R-PTO L L-PTO R</p>
<p>22603039</p>  <ul style="list-style-type: none"> • O-Dichtring • O-ring for air filter • Joint torique pour filtre d'aspiration d'air • Anello di tenuta circolare • O-ring voor 	<p>C22603039</p> <p>IC R-PTO L IC L-PTO R R-PTO L L-PTO R</p>	<p>22479505</p>  <ul style="list-style-type: none"> • Sterngriff • Star knob • Ecrou poigné étoile • Dado manopola a crociera • Ster schroefknop 	<p>C22479505</p> <p>IC R-PTO L IC L-PTO R R-PTO L L-PTO R</p>
<p>23743164</p>  <ul style="list-style-type: none"> • Distanzstück 110x110x60 • Spacer • Pièce d'écartement • Flangia distanziale • Afstandsstuk 	<p>C23743164</p> <p>IC R-PTO L IC L-PTO R</p>	<p>22571491</p>  <ul style="list-style-type: none"> • Distanzstück 110x110x14,5 • Spacer • Pièce d'écartement • Flangia distanziale • Afstandsstuk 	<p>C22571491</p> <p>R-PTO L L-PTO R</p>

<p>22486310</p> 	<ul style="list-style-type: none"> • Distanzstück 110x110x45 • Spacer • Pièce d'écartement • Flangia distanziale • Afstandsstuk 	<p>C22486310</p> <p>IC R-PTO L IC L-PTO R</p>
<p>37600775GHH</p> 	<ul style="list-style-type: none"> • Flachdichtung saugseitig 1,5mm dick DN80 • Flat gasket, suction side • Joint de bride côté aspiration • Guarnizione • Pakking 	<p>37600775</p> <p>Alle Typen All types Toutes var. Tutti versioni Allen typen</p>
<p>23750805</p> 	<p>C23750805</p> <p>Light R-PTO L</p>	<p>23750813</p>  <ul style="list-style-type: none"> • Luftansaugfilter • Suction air filter • Filtre d'air • Filtro aspirazione aria • Aanzuigfilter <p>C23750813</p> <p>Light L-PTO R</p>
<p>22473185</p> 	<p>C22473185</p> <p>Light R-PTO L Light L-PTO R</p>	<p>22723079</p>  <ul style="list-style-type: none"> • Luftfilterdeckel • Air filter cover • Couvercle de filtre d'aspiration d'air • Coperchio filtro aspirazione aria • Luchtfilterdeksel <p>C22723079</p> <p>Light R-PTO L Light L-PTO R</p>
<p>83904235GHH</p> 	<ul style="list-style-type: none"> • Filtereinsatz 310x230x30mm • Filter cartridge • Element filtrant • Cartucce per filtro • Filterelement 	<p>83904235</p> <p>Light R-PTO L Light L-PTO R</p>
<p>22995955</p> 	<ul style="list-style-type: none"> • Ansaugleitung-Kit ohne Zwischenstück • Suction pipe kit without adapter • Ligne d'aspiration kit sans raccord • Kit fissaggio tubo aspirazione senza raccordo • Aanzuigleidingkit zonder tussenstuk 	<p>C22995955</p> <p>Light R-PTO L Light L-PTO R</p>









<p>23101116</p>  <ul style="list-style-type: none"> • Flachdichtung DN86 • Flat gasket • Joint de bride • Guarnizione • Paking 	<p>C23101116</p> <p>Light R-PTO L Light L-PTO R</p>		
<p>22968911</p>  <ul style="list-style-type: none"> • Luftansaugfilter Europiclon mit Regenkappe (12 m³/min.) • Suction air filter Europiclon with rain cap • Filtre d'aspiration d'air Europiclon avec chapeau contre la pluie • Filtro aspirazione aera Europiclon con coperchio • Aanzuigfilter Europiclon met regenkap 	<p>C22968911</p> <p>Optional</p>		
<p>22968929</p>  <ul style="list-style-type: none"> • Halter für Luftfilter 22968911 • Holder for air filter • Cadre support pour filtre d'air • Manicotti per filtro aria • Luchtfitersteunen voor luchtfiter 	<p>C22968929</p> <p>Optional</p>	<p>22968937</p>  <ul style="list-style-type: none"> • Filterpatrone für Luftfilter 22968911 • Filter cartridge for air filter • Element filtrant pour filtre d'air • Cartucce per filtro aria • Filterelement voor luchtfiter 	<p>C22968937</p> <p>Optional</p>
<p>23266562</p>  <ul style="list-style-type: none"> • Luftansaugfilter Europiclon mit Regenkappe (15 m³/min.) • Suction air filter Europiclon with rain cap • Filtre d'aspiration d'air Europiclon avec chapeau contre la pluie • Filtro aspirazione aera Europiclon con coperchio • Aanzuigfilter Europiclon met regenkap 	<p>C23266562</p> <p>Optional</p>		
<p>23266604</p>  <ul style="list-style-type: none"> • Halter für Luftfilter 23266562 • Holder for air filter • Cadre support pour filtre d'air • Manicotti per filtro aria • Luchtfitersteunen voor luchtfiter 	<p>C23266604</p> <p>Optional</p>	<p>23536089</p>  <ul style="list-style-type: none"> • Filterpatrone für Luftfilter 23266562 • Filter cartridge for air filter • Element filtrant pour filtre d'air • Cartucce per filtro aria • Filterelement voor luchtfiter 	<p>C23536089</p> <p>Optional</p>
<p>24667131</p>  <ul style="list-style-type: none"> • Halter für Luftfilter 22968911 + 23266562 • Holder for air filter • Cadre support pour filtre d'air • Manicotti per filtro aria • Luchtfitersteunen voor luchtfiter 	<p>C24667131</p> <p>Optional</p>		









<p>24059263</p>  <ul style="list-style-type: none"> • Luftfilter PSD 9–13m³/min (90°) • Air filter PSD 9–13m³/min (90°) 	<p>C24059263</p> <p>Optional</p>	<p>24865073</p>  <ul style="list-style-type: none"> • Filterpatrone für PSD-Serie (9-13m³/min) • Filter cartridge for PSD series • Element filtrant pour PSD • Cartucce per filtro aria PSD • Filterelement voor PSD 	<p>C24865073</p> <p>Optional</p>
<p>244667370</p>  <ul style="list-style-type: none"> • Logoblech für 24059263 • Logo sign for 24059263 	<p>C24667370</p> <p>Optional</p>	<p>24667131</p>  <ul style="list-style-type: none"> • Halter für Luftfilter 24059263 • Holder for air filter • Cadre support pour filtre d'air • Manicotti per filtro aria • Luchtfitersteunen voor luchtfiter 	<p>C24667131</p> <p>Optional for L-PTO R</p>
<p>24665374</p>  <ul style="list-style-type: none"> • Halter für Luftfilter 24059263 • Holder for air filter • Cadre support pour filtre d'air • Manicotti per filtro aria • Luchtfitersteunen voor luchtfiter 	<p>C24665374</p> <p>Optional for Light R-PTO L</p>	<p>24669442</p>  <ul style="list-style-type: none"> • Distanzbuchse für Halter 24665374 (Einsatzmenge: 3 pro Halter) • Distance bush for holder 24665374 (Req. quantity: 3 per holder) 	<p>C24669442</p> <p>Optional for Light R-PTO L</p>
<p>47533863001</p>  <ul style="list-style-type: none"> • Wartungsanzeiger • Maintenance indicator • Indicateur d'entretien • Indicatore per manutenzione • Onderhoudsindicator 	<p>N/A</p> <p>Optional</p>	<p>22749543</p>  <ul style="list-style-type: none"> • Schlauchanschlussflansch DN100 • Hose connection • Utricule raccordement • Guarnizione per tubo • Aansluitflens voor slang 	<p>C22749543</p> <p>Light R-PTO L Light L-PTO R</p>
<p>47533560001</p>  <ul style="list-style-type: none"> • Schlauchanschlussflansch 90° • Hose connection 90° • Utricule raccordement • Guarnizione per tubo • Aansluitflens voor slang 	<p>N/A</p> <p>Light R-PTO L Light L-PTO R</p>		
<p>23280233</p>  <ul style="list-style-type: none"> • Spiralschlauch DN100 • Flexible hose • Tuyaux flexible • Tubo flessibile • Spiraalslang 	<p>C23280233</p> <p>Light R-PTO L Light L-PTO R</p>	<p>22480602</p>  <ul style="list-style-type: none"> • Spiralschlauch DN110 • Flexible hose • Tuyaux flexible • Tubo flessibile • Spiraalslang 	<p>C22480602</p> <p>Light R-PTO L Light L-PTO R</p>









23062805	C23062805	 <ul style="list-style-type: none">• Gummimuffe d=101,5 x L=133,5• Rubber collar	Light R-PTO L Light L-PTO R	23394497	C23394497	 <ul style="list-style-type: none">• Gummibogen 90°, d=101,5• Rubber elbow	Light R-PTO L Light L-PTO R
23270804	C23270804	 <ul style="list-style-type: none">• Rohr ALU 110x5 (lfd. m.)• Pipe, alum. (per meter)	Light R-PTO L Light L-PTO R	23420748	C23420748	 <ul style="list-style-type: none">• HT Rohr DN110 (lfd. m.)• HT-pipe (per meter)	Light R-PTO L Light L-PTO R
22682132	C22682132	 <ul style="list-style-type: none">• Schlauchschelle 90–110• Hose clip• Collier de serrage• Cravatta fermatubi• Slangeklem	Light R-PTO L Light L-PTO R	33222002GHH	33222002	 <ul style="list-style-type: none">• Schlauchschelle 100–120• Hose clip• Collier de serrage• Cravatta fermatubi• Slangeklem	Light R-PTO L Light L-PTO R
22480834	C22480834	 <ul style="list-style-type: none">• Schlauchschelle 110–130• Hose clip• Collier de serrage• Cravatta fermatubi• Slangeklem	Light R-PTO L Light L-PTO R				

<p>22486864</p>  <ul style="list-style-type: none"> • Luftansaugdämpfer SD-86 • Air suction silencer • Silencieux aspiration d'air • Ammortizzatore aspirazione aria • Aanzuigdemper 	<p>C22486864</p> <p>IC R-PTO L R-PTO L</p>	<p>22486856</p>  <ul style="list-style-type: none"> • Luftansaugdämpfer SD-86 • Air suction silencer • Silencieux aspiration d'air • Ammortizzatore aspirazione aria • Aanzuigdemper 	<p>C22486856</p> <p>IC L-PTO R L-PTO R</p>
<p>22482178</p> 	<ul style="list-style-type: none"> • Deckeldichtung für Luftansaugdämpfer SD-86 • Cover gasket for air suction silencer • Joint de couvercle pour silencieux aspiration d'air • Guarnizione coperchio per aspirazione aria • Dekselpakking voor aanzuigdemper 	<p>C22482178</p> <p>IC R-PTO L IC L-PTO R R-PTO L L-PTO R</p>	
<p>37600775GHH</p> 	<ul style="list-style-type: none"> • Flachdichtung saugseitig 1,5mm dick DN80 • Flat gasket suction side • Joint de bride côté aspiration • Guarnizione • Pakking 	<p>37600775</p> <p>Alle Typen All types Toutes var. Tutti versioni Allen typen</p>	
<p>22486534</p> 	<ul style="list-style-type: none"> • Druckschalldämpfer DS87 inkl. Rückschlagventil • Discharge silencer DS87 incl. non-return valve • Silencieux de refoulement DS87 avec clapet anti-retour • Silenziatore pressione DS87 compr. valvola di non-ritorno • Persdemper voor DS87 incl. terugslagklep 	<p>C22486534</p> <p>IC R-PTO L IC L-PTO R</p>	
<p>22486682</p> 	<ul style="list-style-type: none"> • Druckschalldämpfer DS87 mit Verlängerung G2,5" inkl. Rückschlagventil • Discharge silencer DS87 with extension G2.5" incl. non-return valve 	<p>C22486682</p> <p>R-PTO L L-PTO R</p>	
<p>22486112</p>  <ul style="list-style-type: none"> • Ausströmkopf-Verlängerung • Discharge silencer head extension 	<p>C22486112</p> <p>IC R-PTO L IC L-PTO R R-PTO L L-PTO R</p>		





<p>83904193GHH</p> 	<ul style="list-style-type: none"> • Flanschdichtung druckseitig für Verlängerung • Flange gasket discharge side for extension • Joint de bride côté refoulement • Guarnizione per prolungamento • Flenspakking voor verlenging 	<p>83904193</p> <p>IC R-PTO L IC L-PTO R R-PTO L L-PTO R</p>	
<p>24224586</p> 	<ul style="list-style-type: none"> • Ausströmkopf DS84/87 mit Schlauchstutzen • Discharge silencer head DS84/87 with hose connection 	<p>C24224586</p> <p>IC R-PTO L IC L-PTO R</p>	
<p>24224594</p>  <ul style="list-style-type: none"> • Ausströmkopf DS84/87 mit 2,5" AG • Discharge silencer head DS84/87 with 2.5" male thread 	<p>C24224594</p> <p>R-PTO L L-PTO R</p>	<p>22486443</p>  <ul style="list-style-type: none"> • Flansch Luftaustritt mit 2,5" AG • Flange for air outlet with 2.5" male thread • Bride pour sortie d'air • Guarnizione per uscita aria • Flens uitlaatluucht 	<p>C22486443</p> <p>Light R-PTO L Light L-PTO R</p>
<p>22603047</p> 	<ul style="list-style-type: none"> • Druckschalldämpfer DSD700 inkl. Rückschlagventil • Discharge silencer incl. non-return valve • Silencieux de refoulement avec clapet anti-retour • Silenziatore pressione compr. valvola di non-ritorno • Persdemper inclusief terugslagklep 	<p>C22603047</p> <p>Light R-PTO L Light L-PTO R</p>	
<p>24478976</p>  <ul style="list-style-type: none"> • Deckblech für Druckschalldämpfer DSD700 • Cover plate for discharge silencer DSD700 	<p>C24478976</p> <p>Light R-PTO L Light L-PTO R</p>	<p>24519407</p>  <ul style="list-style-type: none"> • Deckblech-Kit für Druckschalldämpfer DSD700 • Cover plate kit for discharge silencer DSD700 	<p>C24519407</p> <p>Light R-PTO L Light L-PTO R</p>
<p>12792GHH</p>  <ul style="list-style-type: none"> • Druckschalldämpfer-Kopf • Discharge silencer head • Tête de silencieux de refoulement • Persdemperkop 	<p>12792</p> <p>Light R-PTO L Light L-PTO R</p>	<p>22485031</p>  <ul style="list-style-type: none"> • Blindstopfen 2,5" • Blind plug • Plot de remplissage • Tappo • Blindplug 	<p>C22485031</p> <p>IC R-PTO L IC L-PTO R</p>











<p>14824GHH</p> 	<ul style="list-style-type: none"> • Dichtung weiß für 22485031 • O-Ring white for 22485031 	<p>14824</p> <p>IC R-PTO L IC L-PTO R</p>			
<p>22480560</p> 	<ul style="list-style-type: none"> • Rückschlagventil RV-50.1 • Non-return valve • Soupape anti-retour • Valvola di non-ritorno • Terugslagklep 	<p>C22480560</p> <p>Alle Typen All types Toutes var. Tutti versioni Allen typen</p>	<p>22554794</p> 	<ul style="list-style-type: none"> • Dichtung DN50 für RV-50.1 (Einsatzmenge: 2 p. Ventil) • Gasket DN50 for RV-50.1 (Req. quantity: 2 per valve) • Joint d'étanchéité du soupape • Guarnizione • Afdichtingskit 	<p>C22554794</p> <p>Alle Typen All types Toutes var. Tutti versioni Allen typen</p>
<p>24064420</p> 	<ul style="list-style-type: none"> • Druckschalldämpfer DSD700 „NSG“ inkl. Rückschlagventil • Discharge silencer DSD700 „NSG“ incl. non-return valve 	<p>C24064420</p> <p>Light R-PTO L Light L-PTO R</p>	<p>24341174</p> 	<ul style="list-style-type: none"> • Deckblech für Druckschalldämpfer DSD700 „NSG“ • Cover plate for discharge silencer DSD700 „NSG“ 	<p>C24341174</p> <p>Light R-PTO L Light L-PTO R</p>
<p>24617078</p> 	<ul style="list-style-type: none"> • Druckschalldämpfer DSD700 „NSG“ Nachrüstkit • Discharge silencer DSD700 „NSG“ retrofit kit 	<p>C24617078</p> <p>Light R-PTO L Light L-PTO R</p>			
<p>83901289GHH</p> 	<ul style="list-style-type: none"> • Sicherheitsventil G 1 1/2", 2,6 bar • Safety relief valve • Soupape de sûreté • Valvola di sicurezza • Overdrukventiel 	<p>83901289</p> <p>Alle Typen All types Toutes var. Tutti versioni Allen typen</p>			
<p>37600776GHH</p> 	<ul style="list-style-type: none"> • Flachdichtung druckseitig 2,0mm dick DN70 • Flat gasket, discharge side • Joint de bride côté refoulement • Guarnizione • Pakking 	<p>37600776</p> <p>Alle Typen All types Toutes var. Tutti versioni Allen typen</p>			







<p>22515159</p>  <ul style="list-style-type: none"> • Druckluftkühler • Discharge air cooler • Réfrigérant d'air de refoulement • Ventilatore forzato • Drukluftkoeler 	<p>C22515159</p> <p>IC R-PTO L</p>	<p>22515142</p>  <ul style="list-style-type: none"> • Druckluftkühler • Discharge air cooler • Réfrigérant d'air de refoulement • Ventilatore forzato • Drukluftkoeler 	<p>C22515142</p> <p>IC L-PTO R</p>
<p>22477996</p>  <ul style="list-style-type: none"> • Elektrolüfter 24 Volt • Electric fan • Ventilateur électronique • Ventilatore per refrigeratore aria • Ventilator 	<p>C22477996</p> <p>IC R-PTO L IC L-PTO R</p>	<p>83904184GHH</p>  <ul style="list-style-type: none"> • Schlauchschelle DN60 • Hose clip • Collier de serrage • Cravatta fermatubi • Slangeklem 	<p>83904184</p> <p>IC R-PTO L IC L-PTO R</p>
<p>22622732</p>  <ul style="list-style-type: none"> • Verbindungsschlauch DN60x9x160 oben • Flexible hose, top • Tuyaux de raccord • Raccordo a tubo flessibile • Verbindingslang 	<p>C22622732</p> <p>IC R-PTO L IC L-PTO R</p>	<p>22622724</p>  <ul style="list-style-type: none"> • Verbindungsschlauch DN60x9x220 unten • Flexible hose, bottom • Tuyaux de raccord • Raccordo a tubo flessibile • Verbindingslang 	<p>C22622724</p> <p>IC R-PTO L IC L-PTO R</p>
<p>22486427</p>  <ul style="list-style-type: none"> • Zwischendruckleitung • Interstage pressure pipe • Conduite rigide de refoulement intermédiaire • Tubazione di mandata intermedia • Verbindingsdrukleiding 	<p>C22486427</p> <p>IC R-PTO L IC L-PTO R</p>	<p>22598536</p>  <ul style="list-style-type: none"> • Distanzstück 110x110x25 • Spacer • Pièce d'écartement • Flangia distanziale • Afstandsstuk 	<p>C22598536</p> <p>IC R-PTO L IC L-PTO R</p>
<p>22486419</p> 	<p>C22486419</p> <ul style="list-style-type: none"> • Verlängerung 90° für Zwischendruckleitung • Extension 90° for interstage pressure pipe • Allonge 90° pour conduite rigide de refoulement intermédiaire • Prolungamento 90° per tubazione di mandata intermedia • Verlengstuk 90° voor verbindingsdrukleiding 	<p>C22486419</p> <p>IC R-PTO L IC L-PTO R</p>	
<p>22659619</p> 	<p>C22659619</p> <ul style="list-style-type: none"> • Verlängerung für Zwischendruckleitung 2,5", gerade • Extension for interstage pressure pipe 2.5", straight • Allonge conduite rigide droite de refoulement intermédiaire 2,5" • Prolungamento per tubazione dritta di mandata intermedia 2,5" • Verlengstuk voor verbindingsdrukleiding, recht 2,5" 	<p>C22659619</p> <p>IC R-PTO L IC L-PTO R</p>	









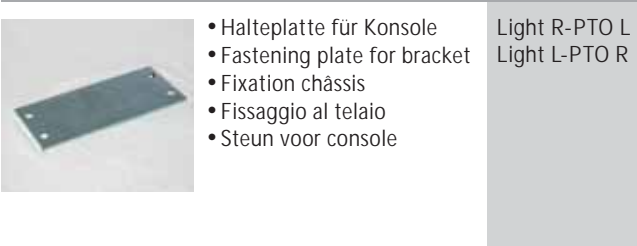

<p>2336610</p> 	<p>• Steuerkontrollgerät • Control unit • Boîtier de contrôle/commande • Dispositivo controllo di comando • Control unit</p>	<p>C2336610 IC R-PTO L IC L-PTO R</p>
<p>2336625</p>  <p>• Manometer 0–3–16 bar • Pressure gauge • Manomètre • Manometro • Manometer</p>	<p>C2336625 IC R-PTO L IC L-PTO R R-PTO L L-PTO R</p>	<p>22569248</p>  <p>• Reduzier-Stück für Manometer • Reducer for manometer</p> <p>C22569248 IC R-PTO L IC L-PTO R R-PTO L L-PTO R</p>
<p>83903302GHH</p>  <p>• Wartungsanzeiger • Maintenance indicator • Indicateur d'entretien • Indicatore per manutenzione • Onderhoudsindicator</p>	<p>83903302 Alle Typen All types Toutes var. Tutti versioni Allen typen</p>	<p>22530190</p>  <p>• Haltebügel Wartungsan- zeige • Holding bow maintenance indicator</p> <p>C22530190 R-PTO L L-PTO R</p>
<p>23371511</p>  <p>• Schlauch DN2x190 • Hose • Tuyaux • Tubo • Slang</p>	<p>C23371511 IC R-PTO L IC L-PTO R</p>	<p>23928658</p>  <p>• Regelelektronik komplett YG 39-E • Electronic control • Ens. électronique de régulation • Sistema elettronico regolazione • Electronische regeleenheid</p> <p>C23371511 IC R-PTO L IC L-PTO R</p>
<p>22571830</p> 	<p>• Temperaturanzeiger für Steuerkontrollgerät • Temperature indicator for control unit • Indicateur de température pour boîtier de contrôle • Indicatore di temperatura • Temperatuur indicator voor control unit</p>	<p>C22571830 IC R-PTO L IC L-PTO R</p>
<p>24211914</p> 	<p>• Hauptschalter zweistufig für SKG • Main switch double-stage for control unit</p>	<p>C24211914 IC R-PTO L IC L-PTO R</p>

<p>22571855</p>  <ul style="list-style-type: none"> • Wahlschalter Dauerbetrieb • Selector switch continuous duty • Interrupteur sélecteur service continu • Interruttore • Keuzeschakelaar continuebedrijf 	<p>C22571855</p> <p>IC R-PTO L IC L-PTO R</p>	<p>22571863</p>  <ul style="list-style-type: none"> • Drehzahlsteller Potentiometer • Speed regulator • Régulateur de vitesse • Regolatore numero di giri • Potentiometer 	<p>C22571863</p> <p>IC R-PTO L IC L-PTO R</p>
<p>83904429GHH</p>  <ul style="list-style-type: none"> • Öl druckschalter 1polig alte Ausführung • Oil pressure switch 1-pole old design 	<p>83904429</p> <p>IC R-PTO L IC L-PTO R</p>	<p>24626954</p>  <ul style="list-style-type: none"> • Kontrollleuchtdiode IP67 • Control diode IP67 • Diode de contrôle IP67 • Diode IP67 • Controlelicht diode IP67 	<p>C24626954</p> <p>IC R-PTO L IC L-PTO R</p>
<p>22940506</p>  <ul style="list-style-type: none"> • Fernthermometer-Geber elektr. 2-polig • Thermometer 2-pole • Capteur électr. bipolaire de téléthermomètre • Indicatore di temperatura 2-poli • Thermometer 2-polig 	<p>C22940506</p> <p>IC R-PTO L IC L-PTO R</p>	<p>22940613</p>  <ul style="list-style-type: none"> • Umrüstkit Fernthermometer • Changeover kit remote thermometer • Kit de modification pour téléthermomètre • Kit modificazione indicatore di temperatura • Modificatiekit Thermometer 	<p>C22940613</p> <p>IC R-PTO L IC L-PTO R</p>
<p>14759GHH</p>  <ul style="list-style-type: none"> • Hochstrom-Sicherungshalter • Fuse holder • Porte-fusible • Portafusibile • Zekeringhouder 	<p>14759</p> <p>IC R-PTO L IC L-PTO R</p>	<p>14760GHH</p>  <ul style="list-style-type: none"> • Sicherungsstreifen 30 Amp. • Safety bar • Bande de protection • Striscetta di controllo • Beveiligingsstrips 	<p>14760</p> <p>IC R-PTO L IC L-PTO R</p>
<p>23094048</p> 	<p>C23094048</p> <ul style="list-style-type: none"> • Steckverbinder DUCON komplett, wasserdicht • DUCON connector complete, waterproof • Connecteur DUCON complet, étanche • Giunto a spine DUCON compl., impermeabile all'acqua • Stekkerverbinding DUCON compleet, waterdicht 	<p>C23094048</p> <p>IC R-PTO L IC L-PTO R</p>	
<p>22532154</p> 	<p>C22532154</p> <ul style="list-style-type: none"> • Schlauchleitung Öl druckmanometer 360mm • Flexible hose oil pressure gauge • Tuyaux pour manomètre d'huile • Tubo flessibile per manometro olio • Flexibele leiding voor oliedrukmeter 	<p>C22532154</p> <p>IC R-PTO L L-PTO R</p>	

<p>22532162</p> 	<p>C22532162</p> <ul style="list-style-type: none"> • Schlauchleitung Öldruckmanometer 500mm • Flexible hose oil pressure gauge • Tuyaux pour manomètre d'huile • Tubo flessibile per manometro olio • Flexibele leiding voor oliedrukmeter 	<p>C22532162</p> <p>IC L-PTO R IC R-PTO L</p>	
<p>23449085</p> 	<p>C23449085</p> <ul style="list-style-type: none"> • Schlauch DN2x320 • Hose • Tuyaux • Tubo • Slang 	<p>C23449085</p> <p>IC R-PTO L IC L-PTO R</p>	
<p>22532170</p> 	<p>C22532170</p> <ul style="list-style-type: none"> • Schlauchleitung Wartungsanzeiger 550mm • Flexible hose line for maintenance indicator • Tuyaux pour indicateur d'entretien • Tubo flessibile per indicatore • Flexibele leiding voor onderhouds indicatop 	<p>C22532170</p> <p>R-PTO L L-PTO R</p>	
<p>22787980</p>  <ul style="list-style-type: none"> • Rohrfedermanometer für Öldruck 0–4 bar • Oil pressure gauge • Manomètre de pression d'huile • Manometro pressione olio • Oliedrukmeter 	<p>C22787980</p> <p>Light R-PTO L Light L-PTO R</p>	<p>23262140</p>  <ul style="list-style-type: none"> • Verschraubung für Ölmanometer (Winkel) • Fitting for oil gauge • Raccord à vis pour manomètre à huile • Raccordo a vite per manometro d'olio • Fitting voor de oliedrukmeter 	<p>36335000</p> <p>Light R-PTO L Light L-PTO R</p>

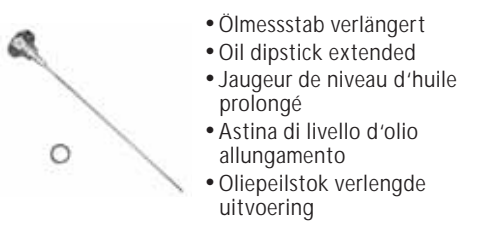
<p>22512628-ATO*</p>  <ul style="list-style-type: none"> • Montagekonsole mit Antrieb • Bracket with drive • Console de montage avec commande • Supporto di montaggio con trasmissione • Montageconsole compleet met aandrijving 	<p>C22512628</p> <p>IC R-PTO L R-PTO L</p>	<p>22512610-ATO*</p>  <ul style="list-style-type: none"> • Montagekonsole kompl. mit Antrieb • Bracket complete with drive • Console de montage avec commande • Supporto di montaggio con trasmissione • Montageconsole compleet met aandrijving 	<p>C22512610</p> <p>IC L-PTO R L-PTO R</p>
<p>22512644-ATO*</p>  <ul style="list-style-type: none"> • Montagekonsole kompl. mit Antrieb • Bracket complete with drive • Console de montage avec commande • Supporto di montaggio con trasmissione • Montageconsole compleet met aandrijving 	<p>C22512644</p> <p>Light R-PTO L</p>	<p>22512636-ATO*</p>  <ul style="list-style-type: none"> • Montagekonsole kompl. mit Antrieb • Bracket complete with drive • Console de montage avec commande • Supporto di montaggio con trasmissione • Montageconsole compleet met aandrijving 	<p>C22512636</p> <p>Light L-PTO R</p>
<p>22497358</p>  <ul style="list-style-type: none"> • Montagekonsole ohne Antrieb • Bracket without drive • Console de montage sans commande • Supporto di montaggio senza trasmissione • Montageconsole zonder aandrijving 	<p>C22497358</p> <p>IC R-PTO L R-PTO L Light R-PTO L</p>	<p>22497325</p>  <ul style="list-style-type: none"> • Montagekonsole ohne Antrieb • Bracket without drive • Console de montage sans commande • Supporto di montaggio senza trasmissione • Montageconsole zonder aandrijving 	<p>C22497325</p> <p>IC L-PTO R L-PTO R Light L-PTO R</p>
<p>22793129</p>  <ul style="list-style-type: none"> • Rahmenbefestigung für Konsole • Frame fastening for bracket • Fixation châssis pour console de montage • Fissaggio al telaio • Framebevestiging voor console 	<p>C22793129</p> <p>Alle Typen All types Toutes var. Tutti versioni Allen typen</p>	<p>23460066</p>  <ul style="list-style-type: none"> • Ausgleichskeil MAN TGX/TGS Radstand 3600mm • Angle shim 	<p>C23460066</p> <p>Alle Typen All types Toutes var. Tutti versioni Allen typen</p>
<p>49005333</p>  <ul style="list-style-type: none"> • Rahmenbefestigung für MAN, Radstand 3600 mm • Frame fastening for bracket for MAN, wheel base 3600 mm 	<p>N/A</p> <p>Alle Typen All types Toutes var. Tutti versioni Allen typen</p>	<p>24087348</p>  <ul style="list-style-type: none"> • Rahmenbefestigung verbreitert für Actros 4 • Frame fastening for bracket broadened for Actros 4 	<p>C24087348</p> <p>Alle Typen All types Toutes var. Tutti versioni Allen typen</p>
<p>23931611</p>  <ul style="list-style-type: none"> • Kit-Schrauben für Rahmenbefestigung • Screw-kit for frame fastening for bracket • Visser pour fixation de cadre • Viti per telaio di fissaggio • Schroeven voor frame monteren 	<p>C23931611</p> <p>Alle Typen All types Toutes var. Tutti versioni Allen typen</p>		

<p>22486922</p> 	<p>C22486922</p> <ul style="list-style-type: none"> • Lagerbock/Antriebkonsole inkl. Gelenkwellenflansch und Spannvorrichtung • Bearing pedestal incl. drive shaft flange and mounting clamps • Support de palier/console entrainement avec joint onduler de bride et dispositif de serrage • Cavalletto del cuscinetto/supporto motore con flangia per giunto e fissaggio • Lagerblok met aandrijving inkl. aandrijfflens en spaninrichting 	<p>C22486922</p> <p>IC R-PTO L R-PTO L Light R-PTO L</p>	
<p>22488266</p> 	<p>C22488266</p> <ul style="list-style-type: none"> • Lagerbock/Antriebkonsole inkl. Gelenkwellenflansch und Spannvorrichtung • Bearing pedestal incl. drive shaft flange and mounting clamps • Support de palier/console entrainement avec joint onduler de bride et dispositif de serrage • Cavalletto del cuscinetto/supporto motore con flangia per giunto e fissaggio • Lagerblok met aandrijving inkl. aandrijfflens en spaninrichting 	<p>C22488266</p> <p>IC L-PTO R L-PTO R Light L-PTO R</p>	
<p>22513006</p> 	<p>C22513006</p> <ul style="list-style-type: none"> • Gelenkwellenflansch, Rechtsgewinde • Drive shaft flange, right-hand thread • Joint onduler de bride, filet à droite • Flangia per giunto, filettatura a destra • Aandrijfflens, rechtse schroefdraad 	<p>C22513006</p> <p>IC R-PTO L R-PTO L Light R-PTO L</p>	
<p>22512990</p> 	<p>C22512990</p> <ul style="list-style-type: none"> • Gelenkwellenflansch, Linksgewinde • Drive shaft flange, left-hand thread • Joint onduler de bride, filet à gauche • Flangia per giunto, filettatura a sinistra • Aandrijfflens, linkse schroefdraad 	<p>C22512990</p> <p>IC L-PTO R L-PTO R Light L-PTO R</p>	
<p>22573216</p> 	<p>C22573216</p> <ul style="list-style-type: none"> • Spannvorrichtung für Keilriemenantrieb • Mounting clamps for V-belt drive • Dispositif de serrage pour courroie trapézoidale • Fissaggio per gruppo cinghie trapezoidali • Spaninrichting voor V-snaar aandrijving 	<p>C22573216</p> <p>Alle Typen All types Toutes var. Tutti versioni Allen typen</p>	
<p>22497366</p>  <ul style="list-style-type: none"> • Halteplatte für Kühler • Fastening plate for cooler • Fixation châssis • Fissaggio al telaio • Steun voor koeler 	<p>C22497366</p> <p>IC R-PTO L IC L-PTO R R-PTO L L-PTO R</p>	<p>22497374</p>  <ul style="list-style-type: none"> • Halteplatte für Konsole • Fastening plate for bracket • Fixation châssis • Fissaggio al telaio • Steun voor console 	<p>C22497374</p> <p>Light R-PTO L Light L-PTO R</p>







<p>22480701</p> 	<p>• Festkupplung Storz B 2,5" IG • Storz B coupling 2.5" female thread</p>	<p>C22480701</p> <p>Alle Typen All types Toutes var. Tutti versioni Allen typen</p>	
<p>22480693</p> 	<p>• Blindeckel mit Kette Storz B • Blind cap with chain Storz B • Couvercle aveugle avec chaîne Storz B • Coperchio con catena Storz B • Blindkap met ketting Storz B</p>	<p>C22480693</p> <p>Alle Typen All types Toutes var. Tutti versioni Allen typen</p>	
<p>22952337</p>  <p>• Festkupplung LM franz. Gr. 80 ohne Arretierung 2,5" IG • Fixed coupling LM French size 80 w/o catch 2.5" female thread</p>	<p>C22952337</p> <p>Alle Typen All types Toutes var. Tutti versioni Allen typen</p>	<p>22914147</p>  <p>• Festkupplung, Blindeckel LM franz. Gr. 80 • Blind cap LM French size 80 • Couvercle aveugle LM dim. française 80 • Coperchio LM francese dim. 80 • Koppeling met blindkap Frans maat 80</p>	<p>C22914147</p> <p>Alle Typen All types Toutes var. Tutti versioni Allen typen</p>
<p>13674GHH</p>  <p>• Kurvenstück TW 518 R 2,5" IG • Male tank wagon coupling, TW 518 R 2,5" IG</p>	<p>13674</p> <p>Light R-PTO L Light L-PTO R</p>	<p>11663GHH</p>  <p>• Blindeckel 3" TW 506 • Blind cap 3" TW 506</p>	<p>11663</p> <p>Light R-PTO L Light L-PTO R</p>
<p>83901297GHH</p>  <p>• Ölmesstab verlängert • Oil dipstick extended • Jaugeur de niveau d'huile prolongé • Astina di livello d'olio allungamento • Oliepeilstok verlengde uitvoering</p>	<p>83901297</p> <p>IC R-PTO L IC L-PTO R R-PTO L L-PTO R</p>	<p>83903276GHH</p>  <p>• Dichtring für Ölmesstab • Sealing ring for oil dipstick</p>	<p>83903276</p> <p>IC R-PTO L IC L-PTO R R-PTO L L-PTO R</p>
<p>22486500</p>  <p>• Rohrverlängerung • Pipe extension</p>	<p>C22486500</p> <p>IC R-PTO L IC L-PTO R R-PTO L L-PTO R</p>	<p>23501547</p>  <p>• Ölansaugsieb • Oil suction filter • Filtre d'huile admettre • Filtro d'olio • Olieaanzuigfilter</p>	<p>63479000</p> <p>CS80 CS104</p>











CS1050

<p>23315112</p>  <ul style="list-style-type: none"> • Abdeckhaube komplett • Cover sheet complete • Couvercle de protection complète • Copertura di protezione completa • Afdekkap compleet 	<p>C23315112</p> <p>IC R-PTO L</p>	<p>23315120</p>  <ul style="list-style-type: none"> • Abdeckhaube komplett • Cover sheet complete • Couvercle de protection complète • Copertura di protezione completa • Afdekkap compleet 	<p>C23315120</p> <p>IC L-PTO R</p>
<p>22485007</p> 		<ul style="list-style-type: none"> • Scharnier F6-942-5 Typ B für Rechtsflügel (Einsatzmenge 2 Stck.) • Frame joint type B (Required quantity 2 pcs.) • Charnière pour support type B • Cerniera per supporto tipo B • Scharnier type B 	<p>C22485007</p> <p>IC R-PTO L</p>
<p>22493993</p> 		<ul style="list-style-type: none"> • Scharnier Typ A für Linksflügel (Einsatzmenge 2 Stck.) • Frame joint type A (Required quantity 2 pcs.) • Charnière pour support type A • Cerniera per supporto tipo A • Scharnier type A 	<p>C22493993</p> <p>IC L-PTO R</p>
<p>22484992</p> 		<ul style="list-style-type: none"> • Scharnier F6-904-5 für flaches Rahmenteil (Einsatzmenge 2 Stck.) • Frame joint for flat frame (Required quantity 2 pcs.) • Charnière pour support • Cerniera per supporto • Scharnier voor vlak framedeel 	<p>C22484992</p> <p>IC R-PTO L IC L-PTO R</p>
<p>15209GHH</p>  <ul style="list-style-type: none"> • Hebelverschluss für Haubenschloss • Latch • Levier de fermeture • Leva di chiusura • Afdekkap grendel 	<p>15209</p> <p>IC R-PTO L IC L-PTO R</p>	<p>15526GHH</p>  <ul style="list-style-type: none"> • Anschlag gerade für Haubenschloss • Mechanical stop for latch • Butée pour levier de fermeture • Bottone per leva di chiusura • Aanslag voor kapversluiting 	<p>15526</p> <p>IC R-PTO L IC L-PTO R</p>
<p>22699417</p> 		<ul style="list-style-type: none"> • Sichtscheibe aus Plexiglas für Abdeckhaube • Viewing glass (plexiglass) for protection sheet • Plaquette de visibilité (plexiglas) pour couvercle • Plachetta visibile (vetro di plexiglas) • Plexiglas kijkglas voor afdekkap 	<p>C22699417</p> <p>IC R-PTO L IC L-PTO R</p>

<p>15523GHH</p> 	<p>15523</p> <ul style="list-style-type: none"> • Schutzkappe für Schraube M12 • Protective cap for screw • Protection pour vis • Protezione per vite • Beschermkap voor schroef 	<p>IC R-PTO L IC L-PTO R</p>
<p>14445GHH</p> 	<p>14445</p> <ul style="list-style-type: none"> • Andrückschraube M8 x 30 • Clamping screw M8 x 30 • Vis de serrage M8 x 30 • Vite di fissaggio M8 x 30 • Klemschroef M8 x 30 	<p>IC R-PTO L IC L-PTO R</p>
<p>22485189</p> 	<p>C22485189</p> <ul style="list-style-type: none"> • Kühlerblech • Cover plate for cooler • Coiffe pour réfrigérant • Protezione per refrigeratore • Afdekkap voor koeler 	<p>IC R-PTO L IC L-PTO R</p>
<p>22488779</p> 	<p>C22488779</p> <ul style="list-style-type: none"> • Abdeckung für Kühlerblech, links oben • Cover sheet for cooler, l-h side top • Couvercle pour coiffe pour réfrigérant, gauche en haut • Coperchio protezione per refrigeratore, parte superiore a sinistra • Afdekkap voor koeler, links boven 	<p>IC R-PTO L</p>
<p>22494041</p> 	<p>C22494041</p> <ul style="list-style-type: none"> • Abdeckung für Kühlerblech, rechts oben • Cover sheet for cooler, r-h side top • Couvercle pour coiffe pour réfrigérant, droite en haut • Coperchio protezione per refrigeratore, parte superiore a destra • Afdekkap voor koeler, rechts boven 	<p>IC L-PTO R</p>
<p>22488803</p> 	<p>C22488803</p> <ul style="list-style-type: none"> • Luftleitblech für Kühlerblech, unten • Baffle plate for cooler plate, bottom • Déflecteur d'air pour coiffe pour réfrigérant, en bas • Lamiera per tubo dell'aria, parte inferiore • Luchtgeleidingsplaat voor koelerkap, onder 	<p>IC R-PTO L IC L-PTO R</p>





<p>22488787</p>  <ul style="list-style-type: none"> • Wärmeleitblech • Heat baffle plate version • Déflecteur thermique • Telaio per calore • Warmtegeleidingsplaat 	<p>C22488787</p> <p>IC R-PTO L</p>	<p>22494058</p>  <ul style="list-style-type: none"> • Wärmeleitblech • Heat baffle plate version • Déflecteur thermique • Telaio per calore • Warmtegeleidingsplaat 	<p>C22494058</p> <p>IC L-PTO R</p>
<p>22485049</p> 		<ul style="list-style-type: none"> • Halter für Keilriemenabdeckung • Holder for V-belt cover 	<p>C22485049</p> <p>IC R-PTO L IC L-PTO R</p>
<p>22485197</p>  <ul style="list-style-type: none"> • Keilriemenabdeckung • V-belt cover • Cadre support pour courroie trapézoïdale • Supporto per cinghie trapezoidali • V-riembeschermkap 	<p>C22485197</p> <p>IC R-PTO L</p>	<p>22968895</p>  <ul style="list-style-type: none"> • Keilriemenabdeckung • V-belt cover • Cadre support pour courroie trapézoïdale • Supporto per cinghie trapezoidali • V-riembeschermkap 	<p>C22968895</p> <p>IC L-PTO R</p>
<p>22496897</p>  <ul style="list-style-type: none"> • Keilriemenabdeckung • V-belt cover • Cadre support pour courroie trapézoïdale • Supporto per cinghie trapezoidali • V-riembeschermkap 	<p>C22496897</p> <p>Light R-PTO L Light L-PTO R</p>		









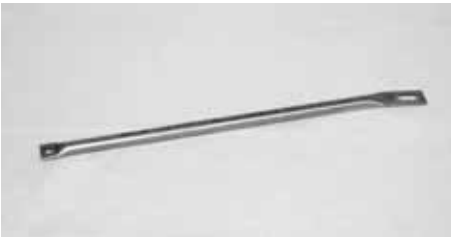

<p>23749393</p> 	<p>C23749393</p> <ul style="list-style-type: none"> • Luftansaugfilter • Suction air filter • Filtre d'air • Filtro aspirazione aria • Aanzuigfilter 	<p>C23749393</p> <p>IC R-PTO L Light R-PTO L</p>	
<p>23749401</p> 	<p>C23749401</p> <ul style="list-style-type: none"> • Luftansaugfilter • Suction air filter • Filtre d'air • Filtro aspirazione aria • Aanzuigfilter 	<p>C23749401</p> <p>IC L-PTO R Light L-PTO R</p>	
<p>22485148</p>  <ul style="list-style-type: none"> • Luftfilterdeckel • Air filter cover • Couvercle de filtre d'aspiration d'air • Coperchio filtro aspirazione aria • LuchtfILTERDEKSEL 	<p>C22485148</p> <p>Alle Typen All types Toutes var. Tutti versioni Allen typen</p>	<p>83904885GHH</p>  <ul style="list-style-type: none"> • Filterelement • Filter cartridge • Element filtrant • Gruppo cartucce per filtro • Filterelement 	<p>83904885</p> <p>Alle Typen All types Toutes var. Tutti versioni Allen typen</p>
<p>22485106</p>  <ul style="list-style-type: none"> • Distanzstück, unten • Spacer, bottom • Piéce d'écartement, en bas • Flangia distanziale, parte inferiore • Afstandsstuk, onder 	<p>C22485106</p> <p>Alle Typen All types Toutes var. Tutti versioni Allen typen</p>	<p>22485098</p>  <ul style="list-style-type: none"> • Distanzstück, oben • Spacer, top • Piéce d'écartement, au-dessus • Flangia distanziale, parte superiore • Afstandsstuk, boven 	<p>C22485098</p> <p>Alle Typen All types Toutes var. Tutti versioni Allen typen</p>
<p>22485155</p> 	<p>C22485155</p> <ul style="list-style-type: none"> • Flachdichtung, oben für Ansaugfilter • Flat gasket, top for suction air filter • Joint de bride • Guarnizione • Pakking 	<p>C22485155</p> <p>Alle Typen All types Toutes var. Tutti versioni Allen typen</p>	
<p>22485163</p> 	<p>C22485163</p> <ul style="list-style-type: none"> • Flachdichtung, unten für Ansaugfilter • Flat gasket, bottom for suction air filter • Joint de bride • Guarnizione • Pakking 	<p>C22485163</p> <p>Alle Typen All types Toutes var. Tutti versioni Allen typen</p>	

<p>83904492GHH</p> 	<ul style="list-style-type: none"> • Flachdichtung saugseitig 1,5mm dick DN100 • Flat gasket suction side • Joint de bride côté aspiration • Guarnizione • Pakking 	<p>83904492</p> <p>Alle Typen All types Toutes var. Tutti versioni Allen typen</p>
<p>22485346</p> 	<ul style="list-style-type: none"> • Rohrbogen 87°, HTB, DN110, PP-H • Elbow pipe • Tube arc • Tubazione • Pijpbochtstuk 	<p>C22485346</p> <p>Alle Typen All types Toutes var. Tutti versioni Allen typen</p>
<p>83904257GHH</p> 	<ul style="list-style-type: none"> • Luftansaugfilter Europiclon mit Regenkappe (21 m³/min.) • Suction air filter Europiclon with rain cap • Filtre d'aspiration d'air Europiclon avec chapeau contre la pluie • Filtro aspirazione aera Europiclon con coperchio • Aanzuigfilter Europiclon met regenkap 	<p>83904257</p> <p>Optional</p>
<p>83904258GHH</p> 	<ul style="list-style-type: none"> • Halter für Luftfilter 83904257GHH, (Einsatzmenge: 2 pro Filter) • Holder for air filter 83904257GHH, (Req. quantity: 2 per filter) • Cadre support pour filtre d'air 83904257GHH • Manicotti per filtro aria 83904257GHH • Luchtfiltersteunen voor luchtfilter 83904257GHH 	<p>83904258</p> <p>Optional</p>
<p>83904259GHH</p> 	<ul style="list-style-type: none"> • Filterpatrone für Luftfilter 83904257GHH • Filter cartridge for air filter 83904257GHH • Element filtrant pour filtre d'air 83904257GHH • Cartucce per filtro aria 83904257GHH • Filterelement voor luchtfilter 8394257GHH 	<p>83904259</p> <p>Optional</p>
<p>22500805</p>  <ul style="list-style-type: none"> • Schlauchanschlussflansch DN110 • Hose connection 	<p>C22500805</p> <p>Optional</p>	<p>47535427001</p>  <ul style="list-style-type: none"> • Schlauchanschlussflansch DN125; 90° • Hose connection <p>Optional</p>

47528053001	N/A		<ul style="list-style-type: none"> • Schlauchanschlussflansch DN130; 90° • Hose connection 	Optional	23497530	C23497530		<ul style="list-style-type: none"> • Schlauchselle 120–140 • Hose clip • Collier de serrage • Cravatta fermatubi • Slangeklem 	Optional
24023723	C24023723		<ul style="list-style-type: none"> • Luftfilter PSD 12-18m³/min (vertikal, 90° Anschluss) • Air filter PSD 12-18m³/min (vertical, 90° stop angle) 	Optional	24028169	C24028169		<ul style="list-style-type: none"> • Filterpatrone für PSD-Serie (12-18m³/min) • Filter cartridge for PSD series • Element filtrant pour PSD • Cartucce per filtro aria PSD • Filterelement voor PSD 	Optional
47542167001	N/A		<ul style="list-style-type: none"> • Logoblech für 24023723 • Logo sign for 24023723 	Optional	47541252001	N/A		<ul style="list-style-type: none"> • Halter für Luftfilter 24023723 • Holder for air filter • Cadre support pour filtre d'air • Manicotti per filtro aria • LuchtfILTERSTEUNEN voor luchtfILTER 	Optional
47533863001	N/A		<ul style="list-style-type: none"> • Wartungsanzeiger • Maintenance indicator • Indicateur d'entretien • Indicatore per manutenzione • Onderhoudsindicator 	Optional	22812945	C22812945		<ul style="list-style-type: none"> • Gummi Reduzierbogen 90° 127,0 / 101,6 • Rubber reducer elbow 	Optional
475347748001	N/A		<ul style="list-style-type: none"> • Gummi-Bogen 90° Di=127 • Rubber elbow 90° Di=127 	Optional	24306599	C24306599		<ul style="list-style-type: none"> • Gummi-Muffe Di=127,0 x L=152,5 • Rubber sleeve 	Optional
23497480	C23497480		<ul style="list-style-type: none"> • Rohr ALU DN130x3 L=80mm • Pipe, alum. 	Optional	23280258	C23280258		<ul style="list-style-type: none"> • Spiralschlauch DN130 • Flexible hose • Tuyaux flexible • Tubo flessibile • Spiraalslang 	Optional

<p>23598832</p>  <ul style="list-style-type: none"> • Luftansaugdämpfer • Air suction silencer • Silencieux aspiration d'air • Ammortizzatore aspirazione aria • Aanzuigdemper 	<p>C23598832</p> <p>IC R-PTO L Light R-PTO L</p>	<p>23598857</p>  <ul style="list-style-type: none"> • Luftansaugdämpfer • Air suction silencer • Silencieux aspiration d'air • Ammortizzatore aspirazione aria • Aanzuigdemper 	<p>C23598857</p> <p>IC L-PTO R Light L-PTO R</p>
<p>83904878GHH</p>  <ul style="list-style-type: none"> • Druckschalldämpfer inkl. Rückschlagklappe • Discharge silencer incl. non-return valve • Silencieux de refoulement • Silenziatore pressione • Persdemper 	<p>83904878</p> <p>Alle Typen All types Toutes var. Tutti versioni Allen typen</p>	<p>83904493GHH</p>  <ul style="list-style-type: none"> • Flachdichtung druckseitig 2,0mm dick DN80 • Flat gasket, discharge side • Joint de bride côté refoulement • Guarnizione • Pakking 	<p>83904493</p> <p>Alle Typen All types Toutes var. Tutti versioni Allen typen</p>
<p>24599110</p>  <ul style="list-style-type: none"> • Druckschalldämpfer „NSG“ IC/Light inkl. Rückschlagventil • Discharge silencer „NSG“ IC/Light incl. non-return valve 	<p>C24599110</p> <p>Alle Typen All types Toutes var. Tutti versioni Allen typen</p>	<p>24603136</p>  <ul style="list-style-type: none"> • Deckblech für Druckschalldämpfer „NSG“ Light • Cover plate for discharge silencer „NSG“ Light 	<p>C24603136</p> <p>Light R-PTO L Light L-PTO R</p>
<p>24885840</p>  <ul style="list-style-type: none"> • Druckschalldämpfer „NSG“ Light Nachrüstkit • Discharge silencer „NSG“ Light retrofit kit 	<p>C24885840</p> <p>Light R-PTO L Light L-PTO R</p>	<p>24478976</p>  <ul style="list-style-type: none"> • Deckblech für alten Druckschalldämpfer 83904878 • Cover plate for old discharge silencer 83904878 	<p>C24478976</p> <p>Light R-PTO L Light L-PTO R</p>
<p>24519407</p>  <ul style="list-style-type: none"> • Deckblech-Kit für alten Druckschalldämpfer 83904878 • Cover plate kit for old discharge silencer 83904878 	<p>C24519407</p> <p>Light R-PTO L Light L-PTO R</p>	<p>12792GHH</p>  <ul style="list-style-type: none"> • Druckschalldämpfer-Kopf • Discharge silencer head • Tête de silencieux de refoulement • Persdemperkop 	<p>12792</p> <p>Alle Typen All types Toutes var. Tutti versioni Allen typen</p>
<p>15410GHH</p>  <ul style="list-style-type: none"> • Druckschalldämpfer-Kopf, kurz • Discharge silencer head, short • Tête de silencieux de refoulement • Persdemperkop 	<p>15410</p> <p>IC L-PTO R</p>	<p>22485031</p>  <ul style="list-style-type: none"> • Blindstopfen 2,5" • Blind plug • Plot de remplissage • Tappo • Blindplug 	<p>C22485031</p> <p>IC R-PTO L IC L-PTO R Light R-PTO L Light L-PTO R</p>

<p>14824GHH</p> 	<ul style="list-style-type: none"> • Dichtung weiß für 22485031 • O-Ring white for 22485031 	<p>14824</p> <p>IC R-PTO L IC L-PTO R</p>	
<p>22487623</p> 	<ul style="list-style-type: none"> • Gewindestopfen 1,5" • Blind plug 	<p>C22487623</p> <p>Alle Typen All types Toutes var. Tutti versioni Allen typen</p>	<p>22593800</p>  <ul style="list-style-type: none"> • Rückschlagklappe • Non-return valve • Soupape anti-retour • Valvola di non-ritorno • Terugslagklep <p>C22593800</p> <p>Alle Typen All types Toutes var. Tutti versioni Allen typen</p>
<p>22554794</p> 		<ul style="list-style-type: none"> • Dichtung DN50 für RV-50.1 (Einsatzmenge: 2 pro Ventil) • Gasket DN50 for RV-50.1 (Req. quantity: 2 per valve) • Joint d'étanchéité du soupape • Guarnizione • Afdichtingskit 	<p>C22554794</p> <p>Alle Typen All types Toutes var. Tutti versioni Allen typen</p>
<p>83901289GHH</p> 		<ul style="list-style-type: none"> • Sicherheitsventil G 1 1/2", 2,6 bar • Safety relief valve • Soupape de sûreté • Valvola di sicurezza • Overdrukventiel 	<p>83901289</p> <p>Alle Typen All types Toutes var. Tutti versioni Allen typen</p>

<p>2362551</p>  <ul style="list-style-type: none"> • Druckluftkühler • Discharge air cooler • Réfrigérant d'air de refoulement • Ventilatore forzato • Drukluftkoeler 	<p>C2362551</p> <p>IC R-PTO L</p>	<p>23625874</p>  <ul style="list-style-type: none"> • Druckluftkühler • Discharge air cooler • Réfrigérant d'air de refoulement • Ventilatore forzato • Drukluftkoeler 	<p>C23625874</p> <p>IC L-PTO R</p>
<p>22901573</p> 	<ul style="list-style-type: none"> • Strebe für Luftkühler • Support for air cooler • Accore pour réfrigérant • Supporto per refrigeratore • Reactiestang voor lucht-koeler 		<p>C22901573</p> <p>IC R-PTO L IC L-PTO R</p>
<p>22485452</p> 	<ul style="list-style-type: none"> • Lüfter (drückend) im ALU-Gehäuse • Fan (blowing) in, alum. housing • Ventilateur (poussant) dans boîte à, alum. • Ventilatore (opprimente) per refrigeratore • Ventilator (drukkend) in, alum. huis 		<p>C22485452</p> <p>IC R-PTO L IC L-PTO R</p>
<p>22481808</p>  <ul style="list-style-type: none"> • Druckrohr DSD/Kühler, oben • Pressure tube disch. silencer/cooler, top • Tube de pression sil. refoul./réfrigérant • Tubo per pressione per DSD/refrigeramento • Perspijp DSD/koeler 	<p>C22481808</p> <p>IC R-PTO L</p>	<p>23028681</p>  <ul style="list-style-type: none"> • Druckrohr DSD/Kühler, oben • Pressure tube discharge silencer/cooler, top • Tube de pression, au-dessus • Tubo per pressione, parte superiore • Perspijp, boven 	<p>C23028681</p> <p>IC L-PTO R</p>
<p>22481782</p>  <ul style="list-style-type: none"> • Druckrohr, unten • Pressure pipe, bottom • Tube de pression, en bas • Tubo a pressione, parte inferiore • Perspijp, onder 	<p>C22481782</p> <p>IC R-PTO L IC L-PTO R</p>	<p>22487516</p>  <ul style="list-style-type: none"> • Flanschdichtung DL-80 • Flange gasket 	<p>C22487516</p> <p>IC R-PTO L IC L-PTO R</p>
<p>22481790</p>  <ul style="list-style-type: none"> • Anschlussflansch H=35mm • Connection flange • Bride de raccordement • Flangia di raccordo • Aansluitflens 	<p>C22481790</p> <p>IC R-PTO L IC L-PTO R</p>	<p>22892301</p>  <ul style="list-style-type: none"> • Anschlussflansch H=27mm • Connection flange • Bride de raccordement • Flangia di raccordo • Aansluitflens 	<p>C22892301</p> <p>IC L-PTO R</p>

<p>22481824</p> 	<ul style="list-style-type: none"> • Heißluftschlauch DN76 x 7,5 bis 240°C (per meter) • Hot-air tube • Tuyaux à l'air chaud • Tubo per aria calda • Hittebestendige slang 	<p>C22481824</p> <p>IC R-PTO L IC L-PTO R</p>
<p>22484976</p> 	<ul style="list-style-type: none"> • Gelenkbolzen-Schelle 86–91mm • Joint bolt hose clip • Collier de serrage avec axe de charnière • Cravatta fermatubi • Slangeklem 	<p>C22484976</p> <p>IC R-PTO L IC L-PTO R</p>
<p>22485254</p> 	<ul style="list-style-type: none"> • Armatureträger, komplett • Control board, complete • Console de contrôle • Controllo con indicatore • Controlle unit 	<p>C22485254</p> <p>IC R-PTO L IC L-PTO R</p>
<p>22544936</p>  <ul style="list-style-type: none"> • Fernthermometer 0–200°C • Remote thermometer • Télèthermomètre • Termometro • Thermometer 	<p>C22544936</p> <p>IC R-PTO L IC L-PTO R</p>	<p>23366925</p>  <ul style="list-style-type: none"> • Manometer 0–3–16 bar • Pressure gauge • Manomètre • Manometro • Manometer <p>C23366925</p> <p>IC R-PTO L IC L-PTO R</p>
<p>22787980</p> 	<ul style="list-style-type: none"> • Rohrfederanometer für Öldruck 0–4 bar • Oil pressure gauge • Manomètre de pression d'huile • Manometro pressione olio • Oliedrukmeter 	<p>C22787980</p> <p>Light R-PTO L Light L-PTO R</p>
<p>23262140</p>  <ul style="list-style-type: none"> • Verschraubung für Ölmanometer (Winkel) • Fitting for oil gauge • Raccord à vis pour manomètre à huile • Raccordo a vite per manometro d'olio • Fitting voor de oliedrukmeter 	<p>36335000</p> <p>Alle Typen All types Toutes var. Tutti versioni Allen typen</p>	<p>22775027</p>  <ul style="list-style-type: none"> • Winkel-Verschraubung EVW-L-06 • Angle fitting EVW-L-06 <p>C22775027</p> <p>Alle Typen All types Toutes var. Tutti versioni Allen typen</p>

<p>83903302GHH</p>  <ul style="list-style-type: none"> •Wartungsanzeiger •Maintenance indicator •Indicateur d'entretien •Indicatore per manutenzione •Onderhoudsindicator 	<p>83903302</p> <p>Light R-PTO L Light L-PTO R</p>	<p>22530190</p>  <ul style="list-style-type: none"> • Haltebügel Wartungsanzeiger • Holding bow for maintenance indicator 	<p>C22530190</p> <p>IC R-PTO L IC L-PTO R</p>
<p>22554802</p> 		<ul style="list-style-type: none"> •Wartungsanzeiger für Ansaugfilter inkl. Adapter, alte Ausführung •Maintenance indicator for air filter incl. adapter, old design •Indicateur d'entretien avec adaptateur •Indicatore per manutenzione con adattatore •Onderhoudsindicator luchtfilter inc. adapter 	<p>C22554802</p> <p>IC R-PTO L IC L-PTO R</p>
<p>22571848</p>  <ul style="list-style-type: none"> •Hauptschalter •Main switch •Interrupteur principal •Interruttore •Hoofdschakelaar 	<p>C22571848</p> <p>IC R-PTO L IC L-PTO R</p>	<p>83904176GHH</p>  <ul style="list-style-type: none"> •LED-Kontrollleuchte, komplett •LED control lamp, complete •Lampe de supervision •Lampadina per controllo •Controlelamp 	<p>83904176</p> <p>IC R-PTO L IC L-PTO R</p>
<p>22554869</p>  <ul style="list-style-type: none"> •Fassung ohne Blende •Frame without screen •Support sans bandeau •Supporto senza vista •Houder zonder glaskap 	<p>C22554869</p> <p>IC R-PTO L IC L-PTO R</p>	<p>22554844</p>  <ul style="list-style-type: none"> •Blende (Glas, grün) •Screen (glass, green) •Bandeau (vitré, verte) •Indicatore (di vetro, verde) •Glaskap (groen) 	<p>C22554844</p> <p>IC R-PTO L IC L-PTO R</p>
<p>22570618</p>  <ul style="list-style-type: none"> •LED-Kontrollleuchte •LED control lamp •Lampe de supervision LED •Lampadina LED per controllo •LED controlelamp 	<p>C22570618</p> <p>IC R-PTO L IC L-PTO R</p>	<p>22554828</p>  <ul style="list-style-type: none"> •Thermoschalter für Kühlventilatoren •Thermo switch for cooling fans •Interrupteur thermostatique pour ventilateurs •Interruttore per ventola •Thermoschakelaar voor koelventilatoren 	<p>C22554828</p> <p>IC R-PTO L IC L-PTO R</p>
<p>15551GHH</p>  <ul style="list-style-type: none"> •Öldruckschalter 0,5 bar •Oil pressure switch •Interrupteur à pression d'huile •Interruttore per pressione d'olio •Oliedrukschakelaar 	<p>15551</p> <p>IC R-PTO L IC L-PTO R</p>		

<p>22968002</p> 	<p>• Widerstand 75W-0R33 5%, für maximale Drehzahl • Resistor 75W-0R33 5%, for max. fan speed</p>	<p>C22968002</p> <p>IC R-PTO L IC L-PTO R</p>
<p>22643886</p> 	<p>• Widerstand 100W 4R7 5%, für reduzierte Lüfterdrehzahl • Resistor 100W 4R7 5%, for reduced fan speed</p>	<p>C22643886</p> <p>IC R-PTO L IC L-PTO R</p>
<p>14759GHH</p>  <p>• Hochstrom-Sicherungshalter • Fuse holder • Porte-fusible • Portafusibile • Zekeringhouder</p>	<p>14759</p> <p>IC R-PTO L IC L-PTO R</p>	<p>14760GHH</p>  <p>• Sicherungsstreifen 30 Amp. • Safety bar • Bande de protection • Striscetta di controllo • Beveiligingsstrips</p> <p>14760</p> <p>IC R-PTO L IC L-PTO R</p>
<p>23094048</p> 	<p>• Steckverbinder DUCON komplett, wasserdicht • DUCON connector complete, waterproof • Connecteur DUCON complet, étanche • Giunto a spine DUCON compl., impermeabile all'acqua • Stekkerverbinding DUCON komplekt, waterdicht</p>	<p>C23094048</p> <p>IC R-PTO L IC L-PTO R</p>
<p>22569248</p>  <p>• Reduzier-Stück für Manometer • Reducer for manometer</p>	<p>C22569248</p> <p>IC R-PTO L IC L-PTO R</p>	<p>10446GHH</p>  <p>• T-Stück für Öldruckschalter • T-piece for oil pressure switch</p> <p>10446</p> <p>IC R-PTO L IC L-PTO R</p>
<p>22480867</p>  <p>• Verschraubung • Fitting • Raccordo • Raccordo • Fitting</p>	<p>C22480867</p> <p>Alle Typen All types Toutes var. Tutti versioni Allen typen</p>	<p>22480800</p>  <p>• Schraubhülse • Collet • Coquille • Conchiglia • Huls</p> <p>C22480800</p> <p>Alle Typen All types Toutes var. Tutti versioni Allen typen</p>

22480594

C22480594



- Schlauch/Hochdruck 8,6 x 4,0mm
- High pressure hose
- Tuyaux pour haute pression
- Tubo per alta pressione
- Hogedrukslang

Alle Typen
All types
Toutes var.
Tutti versioni
Allen typen

15571GHH

15571



- Armatureträger
- Holder for gauges

Light R-PTO L

15572GHH







15572



- Armatureträger
- Holder for gauges

Light L-PTO R

<p>23579964-ATO*</p>  <ul style="list-style-type: none"> • Montagekonsole mit Antrieb • Bracket with drive • Console de montage avec commande • Supporto di montaggio con trasmissione • Montageconsole compleet met aandrijving 	<p>N/A</p> <p>IC R-PTO L</p>	<p>23579972-ATO*</p>  <ul style="list-style-type: none"> • Montagekonsole kompl. mit Antrieb • Bracket complete with drive • Console de montage avec commande • Supporto di montaggio con trasmissione • Montageconsole compleet met aandrijving 	<p>N/A</p> <p>IC L-PTO R</p>
<p>22481857</p>		<p>C22481857</p>	
	<ul style="list-style-type: none"> • Konsole inkl. Wippe • Mounting bracket incl. seesaw • Console pour compresseur • Supporto di montaggio • Compressorconsole 		<p>Alle Typen All types Toutes var. Tutti versioni Allen typen</p>
<p>22707459</p>  <ul style="list-style-type: none"> • Spannwippe für Kompressorkonsole • Seesaw for compressor mounting bracket • Bouton à bascule • Fissaggio per compressore • Spanstoel voor compressorconsole 	<p>C22707459</p> <p>Alle Typen All types Toutes var. Tutti versioni Allen typen</p>	<p>23413719</p>  <ul style="list-style-type: none"> • Spannwippenbolzen M30x440mm mit Stopfmutter M30 • Seesaw bolt M30x440mm with retaining nut M30 	<p>C23413719</p> <p>Alle Typen All types Toutes var. Tutti versioni Allen typen</p>
<p>22632525</p>  <ul style="list-style-type: none"> • Standard-Rahmenbefestigung • Standard frame fastening • Fixation châssis standard • Fissaggio al telaio • Standaard framebevestiging 	<p>C22632525</p> <p>Alle Typen All types Toutes var. Tutti versioni Allen typen</p>	<p>22481840</p>  <ul style="list-style-type: none"> • Montageplatte • Holder for airend • Fixation châssis • Fissaggio al telaio • Steun voor console 	<p>C22481840</p> <p>Alle Typen All types Toutes var. Tutti versioni Allen typen</p>
<p>22552673</p>		<p>C22552673</p>	
	<ul style="list-style-type: none"> • MAN Rahmenbefestigung (Radstand 3,60 m) • Frame fastening MAN (wheelbase 3.60m) • Fixation châssis • Fissaggio al telaio • Framebevestiging 		<p>Alle Typen All types Toutes var. Tutti versioni Allen typen</p>
<p>22485205</p>  <ul style="list-style-type: none"> • Luftkühler-Aufnahme • Holder for air cooler 	<p>C22485205</p> <p>IC R-PTO L</p>	<p>22494009</p>  <ul style="list-style-type: none"> • Luftkühler-Aufnahme • Holder for air cooler 	<p>C22494009</p> <p>IC L-PTO R</p>

<p>23685563</p> 	<p>• Träger für Zyklonfilter 21m³/min • Holder for cyclon filter</p>	<p>C23685563</p> <p>Light R-PTO L Light L-PTO R</p>	
<p>22707442</p> 	<p>• Lagerbock linksdrehend ohne Wippe • Bearing pedestal left-hand drive • Support de palier á gauche • Cavalletto del cuscinetto alla sinistra • Lagerblok linksdraaiend zonder stoel</p>	<p>C22707442</p> <p>IC R-PTO L Light R-PTO L</p>	
<p>22707434</p> 	<p>• Lagerbock rechtsdrehend ohne Wippe • Bearing pedestal right-hand drive • Support de palier á droite • Cavalletto del cuscinetto alla destra • Lagerblok rechtsdraaiend zonder stoel</p>	<p>C22707434</p> <p>IC L-PTO R Light L-PTO R</p>	
<p>24648164 (0,5mm) / 24648172 (1mm)</p> 	<p>• Ausgleichsblech für Lagerbock • Spacer</p>	<p>C24648164 / C24648172</p> <p>Alle Typen All types Toutes var. Tutti versioni Allen typen</p>	
<p>22480685</p> 	<p>• Gelenkwellenflansch DN100-6/8 d=45 • Drive shaft flange • Joint onduler de bride • Flangia per giunto • Aandrijfflens</p>	<p>C22480685</p> <p>Alle Typen All types Toutes var. Tutti versioni Allen typen</p>	
<p>22721963</p>  <p>• Sechskantschraube M16x200 • Hexagon head screw • Vis hexagonal • Bullone esagonale • Zeskant schroef</p>	<p>C22721963</p> <p>Alle Typen All types Toutes var. Tutti versioni Allen typen</p>	<p>22488753</p>  <p>• Schutzkappe für Spannschraube 24/30 lg. • Protective cap for bolt • Protection pour vis • Protezione per vite • Beschermkap voor spanbout</p>	<p>C22488753</p> <p>Alle Typen All types Toutes var. Tutti versioni Allen typen</p>

<p>22484984</p> 	<ul style="list-style-type: none"> • Kupplung Storz B2.5" AG • Coupling Storz B2.5" male thread • Accouplement Storz B • Accoppiamento Storz B • Koppeling Storz B 	<p>C22484984</p> <p>Alle Typen All types Toutes var. Tutti versioni Allen typen</p>	
<p>22480693</p> 	<ul style="list-style-type: none"> • Blinddeckel mit Kette Storz B • Blind cap with chain Storz B • Couvercle aveugle avec chaîne Storz B • Coperchio con catena Storz B • Blindkap met ketting Storz B 	<p>C22480693</p> <p>Alle Typen All types Toutes var. Tutti versioni Allen typen</p>	
<p>22952329</p> 	<p>C22952329</p> <ul style="list-style-type: none"> • Festkupplung LM franz. Gr. 80 mit Arretierung 2,5" AG • Coupling LM French size 80 with catch male thread <p>IC R-PTO L IC L-PTO R</p>	<p>22914147</p> 	<p>C22914147</p> <ul style="list-style-type: none"> • Festkupplung, Blinddeckel LM franz. Gr. 80 • Blind cap LM French size 80 • Couvercle aveugle LM dim. française 80 • Coperchio LM francese dim. 80 • Koppeling met blindkap Frans maat 80 <p>Alle Typen All types Toutes var. Tutti versioni Allen typen</p>
<p>13674GHH</p> 	<p>13674</p> <ul style="list-style-type: none"> • Kurvenstück TW 518 R 2,5" IG • Male tank wagon coupling, TW 518 R 2,5" IG <p>Light L-PTO R Light R-PTO L</p>	<p>11663GHH</p> 	<p>11663</p> <ul style="list-style-type: none"> • Blinddeckel 3" TW 506 • Blind cap 3" TW 506 <p>Light L-PTO R Light R-PTO L</p>
<p>22677058</p> 	<ul style="list-style-type: none"> • Motorwagen-Kit Druckrohrausgang • Discharge-kit for ridget trucks 	<p>C22677058</p> <p>IC R-PTO L IC L-PTO R</p>	
<p>83903982GHH</p> 	<p>83903982</p> <p>CS85</p> <ul style="list-style-type: none"> • Ölmesstab • Oil dipstick • Jauguer de niveau d'huile • Astina di livello d'olio • Oliepeilstok 	<p>24499600</p> 	<p>83903205</p> <p>CS85</p> <ul style="list-style-type: none"> • Ölansaugsieb • Oil intake filter • Filtre d'huile admettre • Filtro d'olio • Olieaanzuigfilter

23286818

C23286818



- Ölmesstab verlängert
- Oil dipstick extended
- Jaugeur de niveau d'huile prolongé
- Astina di livello d'olio allungamento
- Oliepeilstok verlengde uitvoering

Alle Typen
All types
Toutes var.
Tutti versioni
Allen typen

83903276GHH

83903276



- Dichtring für Ölmesstab
- Sealing ring for oil dipstick

Alle Typen
All types
Toutes var.
Tutti versioni
Allen typen

23286768

C23286768















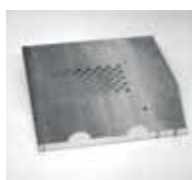



- Rohrverlängerung
- Pipe extension





Alle Typen
All types
Toutes var.
Tutti versioni
Allen typen











CS1200

<p>23667611</p> 	<p>• Abdeckhaube Pos. 1/2 komplett • Cover plate pos. 1/2 complete • Couvercle de protection complète • Copertura di protezione completa • Afdekkap compleet</p>	<p>C23667611</p> <p>IC PTO L IC PTO R</p>
<p>23833445</p> 	<p>• Abdeckhaube Pos. 3/4 komplett • Cover plate pos. 3/4 complete • Couvercle de protection complète • Copertura di protezione completa • Afdekkap compleet</p>	<p>C23833445</p> <p>IC PTO L IC PTO R</p>
<p>23625247</p>  <p>• Sichtfenster • Sight glass • Voyant • Vetro indicatore • Kijkglas</p>	<p>C23625247</p> <p>IC PTO L IC PTO R</p>	
<p>23666993</p>  <p>• Seitenabdeckung Pos. 1/2 • Lateral cover pos. 1/2</p>	<p>C23666993</p> <p>IC PTO L IC PTO R</p>	<p>23829708</p>  <p>• Seitenabdeckung Pos. 3/4 • Lateral cover pos. 3/4</p> <p>C23829708</p> <p>IC PTO L IC PTO R</p>
<p>23667009</p>  <p>• Kühlerabdeckung Pos. 1/2 • Cover for cooler pos. 1/2</p>	<p>C23667009</p> <p>IC PTO L IC PTO R</p>	<p>23829765</p>  <p>• Kühlerabdeckung Pos. 3 • Cover for cooler pos. 3</p> <p>C23829765</p> <p>IC PTO L IC PTO R</p>
<p>23759749</p> 	<p>• Halter für Kühlerabdeckung, oben Pos. 1/2 • Holder for cooler cover, top pos. 1/2</p>	<p>C23759749</p> <p>IC PTO L IC PTO R</p>

<p>23666308</p> 	<p>• Halter für Kühlerabdeckung, unten Pos. 1/2 • Holder for cooler cover, bottom pos. 1/2</p>	<p>C23666308 IC PTO L IC PTO R</p>	
<p>23824436</p> 	<p>• Halter für Kühlerabdeckung, oben Pos. 3/4 • Holder for cooler cover, top pos. 3/4</p>	<p>C23824436 IC PTO L IC PTO R</p>	
<p>23829641</p> 	<p>• Halter für Kühlerabdeckung, unten Pos. 3/4 • Holder for cooler cover, bottom pos. 3/4</p>	<p>C23829641 IC PTO L IC PTO R</p>	
<p>23704828</p>  <p>• Halter für Kühlerblech Pos. 1/2 • Holder for cooler plate pos. 1/2</p>	<p>C23704828 IC PTO L IC PTO R</p>	<p>23824295</p>  <p>• Halter f. Kühlerblech Pos. 3/4 • Holder for cooler plate pos. 3/4</p>	<p>C23824295 IC PTO L IC PTO R</p>
<p>23666316</p>  <p>• Strebe für Luftfilter Pos.1/2 • Bracer for air filter pos. 1/2</p>	<p>C23666316 IC PTO L IC PTO R</p>	<p>23824246</p>  <p>• Strebe für Luftfilter Pos. 3/4 • Bracer for air filter pos. 3/4</p>	<p>C23824246 IC PTO L IC PTO R</p>
<p>23759731</p>  <p>• Halter für Seitenabdeckung • Holder for lateral cover</p>	<p>C23759731 IC PTO L IC PTO R</p>	<p>23870835</p>  <p>• Dichtungsblech ALU • Blanket plate, alum.</p>	<p>C23870835 IC PTO L IC PTO R</p>

23779598  <ul style="list-style-type: none">• Winkelprofil• Angle plate	C23779598 IC PTO L IC PTO R	23778822  <ul style="list-style-type: none">• Gewindeplatte M8 verzinkt• Threaded plate M8 galvanised	C23778822 IC PTO L IC PTO R
23795305 	<ul style="list-style-type: none">• Abdeckung für Luftfilterhalter Pos. 1/2• Cover for air filter holder pos. 1/2	C23795305 IC PTO L IC PTO R	
23824154 	<ul style="list-style-type: none">• Abdeckung für Luftfilterhalter Pos. 3• Cover for air filter holder pos. 3	C23824154 IC PTO L IC PTO R	







<p>23625189</p>  <ul style="list-style-type: none"> • Luftansaugfilter • Suction air filter • Filtre d'aspiration d'air • Filtro aspirazione aera • Aanzuigfilter 	<p>C23625189</p> <p>IC PTO L IC PTO R</p>	<p>23625205</p>  <ul style="list-style-type: none"> • Luftfilterdeckel • Air filter cover 	<p>C23625205</p> <p>IC PTO L IC PTO R</p>
<p>23295868</p>  <ul style="list-style-type: none"> • Filterelement • Filter cartridge • Element filtrant • Cartucce per filtro • Filterelement 	<p>C23295868</p> <p>IC PTO L IC PTO R</p>	<p>22479505</p>  <ul style="list-style-type: none"> • Sterngriff • Star knob • Ecrou poigné étoile • Dado manopola a crociera • Ster schroefknop 	<p>C22479505</p> <p>IC PTO L IC PTO R</p>
<p>23200942</p>  <ul style="list-style-type: none"> • Flachdichtung, saugseitig • Flat gasket, suction side • Joint de bride côté aspiration • Guarnizione • Pakking 		<p>C23200942</p> <p>Alle Typen All types Toutes var. Tutti versioni Allen typen</p>	
<p>23343015</p> 	<ul style="list-style-type: none"> • Schlauchanschlussflansch DN130, 40° gekröpft • Hose connection flange DN130, 40° cranked 		<p>C23343015</p> <p>Light PTO L Light PTO R Interims kit</p>
<p>23343676</p> 	<ul style="list-style-type: none"> • Schlauchanschlussflansch DN130 gerade • Hose connection flange DN130 straight 		<p>C23343676</p> <p>IC PTO L IC PTO R Light PTO L Light PTO R Interims kit</p>
<p>83904257GHH</p> 	<ul style="list-style-type: none"> • Luftansaugfilter Europiclön mit Regenkappe (21 m³/min.) • Suction air filter Europiclön with rain cap • Filtre d'aspiration d'air Europiclön avec chapeau contre la pluie • Filtro aspirazione aera Europiclön con coperchio • Aanzuigfilter Europiclön met regenkap 		<p>83904257</p> <p>Light PTO L Light PTO R Interims kit</p>

<p>83904258GHH</p> 	<ul style="list-style-type: none"> • Halter für Luftfilter 83904257GHH, (Einsatzmenge: 2 pro Filter) • Holder for air filter 83904257GHH, (Req. quantity: 2 per filter) • Cadre support pour filtre d'air 83904257GHH • Manicotti per filtro aria 83904257GHH • Luchtfiltersteunen voor luchtfilter 83904257GHH 	<p>83904258</p> <p>Light PTO L Light PTO R Interims kit</p>	
<p>83904259GHH</p> 	<ul style="list-style-type: none"> • Filterpatrone für Luftfilter 83904257GHH • Filter cartridge for air filter 83904257GHH • Element filtrant pour filtre d'air 83904257GHH • Cartucce per filtro aria 83904257GHH • Filterelement voor luchtfilter 83904257GHH 	<p>83904258</p> <p>Light PTO L Light PTO R Interims kit</p>	
<p>23381098</p> 	<ul style="list-style-type: none"> • Gummi-Bogen 90° Di=130 ohne Anschluss M10x1 • Rubber elbow 90° Di=130 without adapter M10x1 	<p>C23381098</p> <p>Light PTO L Light PTO R Interims kit</p>	
<p>23497480</p>  <ul style="list-style-type: none"> • Rohr ALU DN130x3 L=80mm • Pipe, alum. 	<p>C23497480</p> <p>Light PTO L Light PTO R Interims kit</p>	<p>23280258</p>  <ul style="list-style-type: none"> • Spiralschlauch DN130 • Flexible hose • Tuyaux flexible • Tubo flessibile • Spiraalslang 	<p>C23280258</p> <p>IC PTO L IC PTO R Light PTO L Light PTO R Interims kit</p>
<p>23497530</p>  <ul style="list-style-type: none"> • Schlauchschelle 120–140 • Hose clip • Collier de serrage • Cravatta fermatubi • Slangeklem 	<p>C23497530</p> <p>IC PTO L IC PTO R Light PTO L Light PTO R Interims kit</p>		
<p>23840085</p> 	<ul style="list-style-type: none"> • Luftfilter PSD 12-18m³/min (vertikal) • Air filter PSD 12-18m³/min (vertical) 	<p>C23840085</p> <p>Optional</p>	

24023723 	<ul style="list-style-type: none">• Luftfilter PSD 12-18m³/min (vertikal, 90° Anschluss)• Air filter PSD 12-18m³/min (vertical, 90° stop angle)	C24023723 Optional
24028169 	<ul style="list-style-type: none">• Filterpatrone für PSD-Serie (12-18m³/min)• Filter cartridge for PSD series• Element fi ltrant pour PSD• Cartucce per filtro aria PSD• Filterelement voor PSD	C24028169 Optional
47542167001 	<ul style="list-style-type: none">• Logoblech für 24023723• Logo sign for 24023723	N/A Optional







<p>23639495</p>  <ul style="list-style-type: none"> • Druckschalldämpfer Pos. 1 • Discharge silencer • Silencieux de refoulement • Silenziatore pressione • Persdemper 	<p>C23639495</p> <p>IC PTO L IC PTO R</p>	<p>23834302</p>  <ul style="list-style-type: none"> • Druckschalldämpfer Pos. 2 • Discharge silencer • Silencieux de refoulement • Silenziatore pressione • Persdemper 	<p>C23834302</p> <p>IC PTO L IC PTO R</p>
<p>23834260</p>  <ul style="list-style-type: none"> • Druckschalldämpfer Pos. 3 • Discharge silencer • Silencieux de refoulement • Silenziatore pressione • Persdemper 	<p>C23834260</p> <p>IC PTO L IC PTO R</p>		
<p>23342207</p> 		<ul style="list-style-type: none"> • Flachdichtung Druckausgang Druckschalldämpfer • Flat gasket pressure outlet discharge silencer 	<p>C23342207</p> <p>IC PTO L IC PTO R Light R-PTO L Light L-PTO R</p>
<p>23200959</p> 		<ul style="list-style-type: none"> • Flachdichtung, druckseitig • Flat gasket, discharge side • Joint de bride côté refoulement • Guarnizione • Pakking 	<p>C23200959</p> <p>IC PTO L IC PTO R Light R-PTO L Light L-PTO R Interims kit</p>
<p>23826548</p>  <ul style="list-style-type: none"> • Krümmer druckseitig, 3° Neigung • Manifold discharge side, 3° tilted 	<p>C23826548</p> <p>IC PTO L IC PTO R Interims kit</p>	<p>83904493GHH</p>  <ul style="list-style-type: none"> • Flachdichtung, druckseitig (auch verwendbar für Krümmer 23826548, 23210610, 23518970) • Flat gasket, discharge side (also usable for manifolds 23826548, 23210610, 23518970) 	<p>83904493</p> <p>IC PTO L IC PTO R Interims kit</p>
<p>23625395</p> 		<ul style="list-style-type: none"> • Verbindungsstutzen vom Druckschalldämpfer zum Kühler • Adapter from discharge silencer to air cooler 	<p>C23625395</p> <p>IC PTO L IC PTO R</p>

<p>23342157</p>  <ul style="list-style-type: none"> • Druckschalldämpfer • Discharge silencer • Silencieux de refoulement • Silenziatore pressione • Persdemper 	<p>C23342157</p> <p>Light PTO L Light PTO R</p>	<p>23438872</p>  <ul style="list-style-type: none"> • Rückschlagklappe 3" • Non-return valve • Soupape anti-retour • Valvola di non-ritorno • Terugslagklep 	<p>C23438872</p> <p>IC PTO L IC PTO R Light PTO L Light PTO R</p>
<p>23342215</p> 	<ul style="list-style-type: none"> • Flachdichtung für Rückschlagklappe 3" • Flat gasket for non-return valve • Joint de bride • Guarnizione • Pakking 	<p>C23342215</p> <p>IC PTO L IC PTO R Light PTO L Light PTO R</p>	
<p>23342181</p> 	<ul style="list-style-type: none"> • Druckstutzen mit Innengewinde 3", 133x133mm • Discharge flange with female thread 	<p>C23342181</p> <p>Light PTO L Light PTO R</p>	
<p>23342173</p>  <ul style="list-style-type: none"> • Blinddeckel für Druckschalldämpfer • Blind cap for discharge silencer 	<p>C23342173</p> <p>IC PTO L IC PTO R Light R-PTO L Light L-PTO R</p>		
<p>83901289GHH</p> 	<ul style="list-style-type: none"> • Sicherheitsventil G 1 1/2", 2,6 bar • Safety relief valve • Soupape de sûreté • Valvola di sicurezza • Overdrukventiel 	<p>83901289</p> <p>Alle Typen All types Toutes var. Tutti versioni Allen typen</p>	









<p>23625924</p> 	<ul style="list-style-type: none"> • Luft-Luftkühler mit Lüfterkasten • Air-air cooler with ventilation box 	<p>C23625924</p> <p>IC PTO L IC PTO R</p>
<p>23678667</p> 	<ul style="list-style-type: none"> • Luft-Luftkühler komplett mit Druckstutzen und Rückschlagklappe • Air-air cooler complete with discharge flange and non-return valve 	<p>C23678667</p> <p>IC PTO L IC PTO R</p>
<p>23656523</p> 	<ul style="list-style-type: none"> • Druckstutzen 3" IG / 90° für Luft-Luftkühler • Discharge-side 3" female thread / 90° for air-air cooler 	<p>C23656523</p> <p>IC PTO L IC PTO R</p>
<p>23342207</p> 	<ul style="list-style-type: none"> • Flachdichtung Druckausgang Druckschalldämpfer • Flat gasket pressure outlet discharge silencer 	<p>C23342207</p> <p>IC PTO L IC PTO R Light R-PTO L Light L-PTO R</p>
<p>23656697</p> 	<ul style="list-style-type: none"> • Deckel für Luft-Luftkühler, unten • Cap for air-air cooler, bottom 	<p>C23656697</p> <p>IC PTO L IC PTO R</p>
<p>23673122</p> 	<ul style="list-style-type: none"> • Flachdichtung Luft-Luftkühler, unten • Flat gasket air-air cooler, bottom • Joint de bride côté • Guarnizione • Pakking 	<p>C23673122</p> <p>IC PTO L IC PTO R</p>



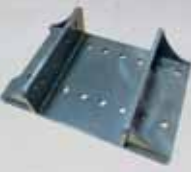





<p>23698475</p>  <ul style="list-style-type: none"> • Elektrolüfter 24V • Electric fan 	<p>C23698475</p> <p>IC PTO L IC PTO R</p>	<p>23673098</p>  <ul style="list-style-type: none"> • Armatureträger, komplett • Control board, complete • Console de contrôle • Controllo con indicatore • Controlo unit 	<p>C23673098</p> <p>IC PTO L IC PTO R</p>
<p>22544936</p>  <ul style="list-style-type: none"> • Fernthermometer 0–200°C • Remote thermometer • Télèthermomètre • Termometro • Thermometer 	<p>C22544936</p> <p>IC PTO L IC PTO R</p>	<p>23366925</p>  <ul style="list-style-type: none"> • Rohrfedermanometer Öldruck 0/3/16 bar, Anschluss hinten • Oil pressure gauge 0/3/16 bar, connection at back side 	<p>C23366925</p> <p>IC PTO L IC PTO R</p>
<p>83903302GHH</p>  <ul style="list-style-type: none"> • Wartungsanzeiger • Maintenance indicator • Indicateur d'entretien • Indicatore per manutenzione • Onderhoudsindicator 	<p>83903302</p> <p>IC PTO L IC PTO R Light PTO L Light PTO R Interims kit</p>	<p>22530190</p>  <ul style="list-style-type: none"> • Haltebügel Wartungsanzeiger • Holding bow maintenance indicator 	<p>C22530190</p> <p>IC PTO L IC PTO R</p>
<p>22571848</p>  <ul style="list-style-type: none"> • Hauptschalter für Steuerkontrollgerät • Main switch for control unit • Interrupteur principal • Interruttore • Hoofdschakelaar 	<p>C22571848</p> <p>IC PTO R IC PTO L</p>	<p>23474505</p>  <ul style="list-style-type: none"> • Regelelektronik ESC • Electronic control • Ens. électronique de régulation • Sistema elettronico regolazione • Electronische regeleenheid 	<p>C23474505</p> <p>IC PTO L IC PTO R</p>
<p>15551GHH</p>  <ul style="list-style-type: none"> • Öldruckschalter 0,5 bar • Oil pressure switch • Interrupteur à pression d'huile • Interruttore per pressione d'olio • Oliedrukschakelaar 	<p>15551</p> <p>IC PTO L IC PTO R Interims kit with remote oil cooler Light with remote oil cooler</p>	<p>23100563</p>  <ul style="list-style-type: none"> • Schutzkappe für Öldruckschalter • Protection cap for oil pressure switch 	<p>C23100563</p> <p>IC PTO L IC PTO R Interims kit with remote oil cooler Light with remote oil cooler</p>
<p>14759GHH</p>  <ul style="list-style-type: none"> • Hochstrom-Sicherungshalter • Fuse holder • Porte-fusible • Portafusibile • Zekeringhouder 	<p>14759</p> <p>IC PTO L IC PTO R Interims kit with remote oil cooler Light with remote oil cooler</p>	<p>14760GHH</p>  <ul style="list-style-type: none"> • Sicherungsstreifen 30 Amp. • Safety bar • Bande de protection • Striscetta di controllo • Beveiligingsstrips 	<p>14759</p> <p>IC PTO L IC PTO R Interims kit with remote oil cooler Light with remote oil cooler</p>

<p>23094048</p> 	<ul style="list-style-type: none"> • Steckverbinder DUCON komplett, wasserdicht • DUCON connector complete, waterproof • Connecteur DUCON complet, étanche • Giunto a spine DUCON compl., impermeabile all'acqua • Stekkerverbinding DUCON kompledt, waterdicht 	<p>C23094048</p> <p>IC PTO L IC PTO R</p>	
<p>22569248</p> 	<p>C22569248</p> <p>IC PTO L IC PTO R</p>	<p>10446GHH</p>  <ul style="list-style-type: none"> • T-Stück für Öldruckschalter • T-piece for oil pressure switch 	<p>10446</p> <p>Alle Typen All types Toutes var. Tutti versioni Allen typen</p>
<p>15452GHH</p> 	<p>15452</p> <p>Light PTO L Light PTO R Interims kit</p>	<p>22787980</p>  <ul style="list-style-type: none"> • Rohrfedermanometer für Öldruck 0-4 bar, Anschluss unten • Oil pressure gauge 0-4 bar, connection at bottom • Manomètre de pression d'huile • Manometro pressione olio • Oljedrukmeter 	<p>C22787980</p> <p>Light PTO L Light PTO R Interims kit</p>
<p>22480800</p> 	<p>C22480800</p> <p>Alle Typen All types Toutes var. Tutti versioni Allen typen</p>	<p>22480867</p>  <ul style="list-style-type: none"> • Verschraubung • Fitting • Raccord • Raccordo • Fitting 	<p>C22480867</p> <p>Alle Typen All types Toutes var. Tutti versioni Allen typen</p>
<p>23550023</p> 	<p>C23550023</p> <p>Alle Typen All types Toutes var. Tutti versioni Allen typen</p>	<p>22775027</p>  <ul style="list-style-type: none"> • Winkel-Verschraubung EVW-L-06 • Angle fitting EVW-L-06 	<p>C22775027</p> <p>Alle Typen All types Toutes var. Tutti versioni Allen typen</p>
<p>23937394</p> 	<p>C23937394</p> <p>Alle Typen All types Toutes var. Tutti versioni Allen typen</p>	<p>23937527</p>  <ul style="list-style-type: none"> • Einsteckverschraubung gerade M10x1K, 6mm mit Raste • Plug and socket connection M10x1K, 6mm with pawl 	<p>C23937527</p> <p>Alle Typen All types Toutes var. Tutti versioni Allen typen</p>

<p>22480594</p> 	<p>C22480594</p> <ul style="list-style-type: none"> • Schlauch/Hochdruck 8,6 x 4,0mm • High pressure hose • Tuyaux pour haute pression • Tubo per alta pressione • Hogedrukslang 	<p>C22480594</p> <p>Alle Typen All types Toutes var. Tutti versioni Allen typen</p>	
<p>23393960</p> 	<p>C23393960</p> <ul style="list-style-type: none"> • Regenkappe für Kühlluftansaugleitung • Rain cap for cooling air suction pipe 	<p>C23393960</p> <p>Alle Typen All types Toutes var. Tutti versioni Allen typen</p>	
<p>23420763</p>  <ul style="list-style-type: none"> • HT Rohr DN125 grau (lfd. m.) • HT-pipe (per meter) 	<p>C23420763</p> <p>Alle Typen All types Toutes var. Tutti versioni Allen typen</p>	<p>22741946</p>  <ul style="list-style-type: none"> • Spiralschlauch DN125 • Flexible hose • Tuyaux flexible • Tubo flessibile • Spiraalslang 	<p>C22741946</p> <p>Alle Typen All types Toutes var. Tutti versioni Allen typen</p>
<p>24031460</p> 	<p>C24031460</p> <ul style="list-style-type: none"> • Befestigungsschelle für HT-Rohr DN125mm • Fastening clip for HT-pipe 	<p>C24031460</p> <p>Alle Typen All types Toutes var. Tutti versioni Allen typen</p>	
<p>23367576</p> 	<p>C23367576</p> <ul style="list-style-type: none"> • Lüfter-Relais-Steuerung (1 Lüfter) inkl. Kabel • Fan relay control unit (1 fan) incl. cable 	<p>C23367576</p> <p>Light R-PTO L Light L-PTO R Interims kit</p>	
<p>23373764</p> 	<p>C23373764</p> <ul style="list-style-type: none"> • Lüfter-Relais-Steuerung (2 Lüfter) inkl. Kabel • Fan relay control unit (2 fans) incl. cable 	<p>C23373764</p> <p>Light R-PTO L Light L-PTO R Interims kit</p>	

11697GHH  <ul style="list-style-type: none">• Ölkühler T1 mit Lüfter 24 Volt• Oil cooler T1 with fan 24 Volt	11697 Remote cooler	13436GHH  <ul style="list-style-type: none">• Reduzierschraubung RI 1" ED-1/4• Reducer connector	13436 Remote cooler
22669055 	<ul style="list-style-type: none">• Einschraubverschraubung, gerade GE 10-PLR-1/4 ED• Male end fitting, straight	C22669055 Remote cooler	









<p>23819774</p>  <ul style="list-style-type: none"> • Montagekonsole • Assembly bracket 	<p>C23819774</p> <p>IC PTO L IC PTO R</p>		
<p>23820533</p>  <ul style="list-style-type: none"> • Rahmenbefestigung Standardausführung, gerade • Frame fastening for bracket, standard, straight • Fixation châssis pour console de montage • Fissaggio al telaio • Framebevestiging voor console 	<p>C23820533</p> <p>IC PTO L IC PTO R</p>	<p>23820541</p>  <ul style="list-style-type: none"> • Rahmenbefestigung Actros 3/Axor/DAF • Frame fastening for bracket • Fixation châssis pour console de montage • Fissaggio al telaio • Framebevestiging voor console 	<p>C23820541</p> <p>IC PTO L IC PTO R</p>
<p>24087587</p>  <ul style="list-style-type: none"> • Rahmenbefestigung verstärkt, Actros 4, Pos. 1+2 • Frame fastening for bracket • Fixation châssis pour console de montage • Fissaggio al telaio • Framebevestiging voor console 	<p>C24087587</p> <p>IC PTO L IC PTO R</p>	<p>23840051</p>  <ul style="list-style-type: none"> • Rahmenbefestigung MAN • Frame fastening for bracket • Fixation châssis pour console de montage • Fissaggio al telaio • Framebevestiging voor console 	<p>C23840051</p> <p>IC PTO L IC PTO R</p>
<p>23840069</p>  <ul style="list-style-type: none"> • Rahmenbefestigung Scania • Frame fastening for bracket • Fixation châssis pour console de montage • Fissaggio al telaio • Framebevestiging voor console 	<p>C23840069</p> <p>IC PTO L IC PTO R</p>	<p>23795354</p>  <ul style="list-style-type: none"> • Zentralhalter Pos. 1–4 • Central holder 	<p>C23795354</p> <p>IC PTO L IC PTO R</p>
<p>23862865</p> 	<ul style="list-style-type: none"> • Halter für Luftfilter, Druckschalldämpfer und Kühler Pos.1 • Holder for air filter, discharge silencer and cooler, pos. 1 	<p>C23862865</p> <p>IC PTO L IC PTO R</p>	
<p>23794464</p> 	<ul style="list-style-type: none"> • Halter für Luftfilter, Druckschalldämpfer und Kühler, Pos.2 • Holder for air filter, discharge silencer and cooler, pos. 2 	<p>C23794464</p> <p>IC PTO L IC PTO R</p>	

<p>23822737</p>  <ul style="list-style-type: none"> • Halter Druckschalldämpfer/ Luftfilter Pos. 3 • Holder discharge silencer/ air filter pos. 3 	<p>C23822737</p> <p>IC PTO L IC PTO R</p>	
<p>23794480</p> 	<p>C23794480</p> <ul style="list-style-type: none"> • Stütze von Konsole zum Druckschalldämpfer, unten Pos. 2 • Support for brack to discharge silencer, bottom pos. 2 <p>IC PTO L IC PTO R</p>	
<p>23822752</p>  <ul style="list-style-type: none"> • Halter für Luftkühler Pos. 3 • Holder for air cooler pos. 3 	<p>C23822752</p> <p>IC PTO L IC PTO R</p>	<p>23797004</p>  <ul style="list-style-type: none"> • Gegenplatte mit Muttern M12 • Counter plate with nuts <p>IC PTO L IC PTO R</p>
<p>23823214</p>  <ul style="list-style-type: none"> • Strebe, oben • Bracer, top 	<p>C23823214</p> <p>IC PTO L IC PTO R</p>	
<p>23759640</p>  <ul style="list-style-type: none"> • Knotenblech Pos. 1/2 • Gusset plate pos. 1/2 	<p>C23759640</p> <p>IC PTO L IC PTO R</p>	<p>23824311</p>  <ul style="list-style-type: none"> • Knotenblech Pos. 3/4 • Gusset plate pos. 3/4 <p>IC PTO L IC PTO R</p>
<p>23365844</p> 	<p>C23365844</p> <ul style="list-style-type: none"> • Konsole DAF 6x2 FTP-4.05m wb • Bracket 	<p>Light R-PTO L Light L-PTO R Interims kit</p>

<p>23365893</p>  <ul style="list-style-type: none"> • Konsole Universal • Universal bracket 	<p>C23365893</p> <p>Light PTO L Light PTO R Interims kit</p>	<p>23365836</p>  <ul style="list-style-type: none"> • Konsole MAN 6x2 • Bracket 	<p>C23365836</p> <p>Light PTO L Light PTO R Interims kit</p>
<p>23667314</p>  <ul style="list-style-type: none"> • Ausgleichskeile-Kit für Actros 3/Axor/DAF • Angle shim kit 		<p>C23667314</p> <p>Light PTO L Light PTO R Interims kit</p>	
<p>23638299</p>  <ul style="list-style-type: none"> • Ausgleichskeile-Kit für an Scania (2.7°) • Angle shim kit 		<p>C23638299</p> <p>Light PTO L Light PTO R Interims kit</p>	
<p>23656143</p>  <ul style="list-style-type: none"> • Ausgleichskeile-Kit für an MAN (4.5°) • Angle shim kit 		<p>C23656143</p> <p>Light PTO L Light PTO R Interims kit</p>	
<p>Diverse</p>  <ul style="list-style-type: none"> • Distanzstück-Kits / Spacer kits: • 47583893001 (10 mm) • 47583894001 (20 mm) 		<p>C23365919</p> <p>Light PTO L Light PTO R Interims kit</p>	
<p>23680440</p>  <ul style="list-style-type: none"> • Montage- und Transporthalter Pos.1/2 • Assembly and transport holder 	<p>C23680440</p> <p>IC PTO L IC PTO R</p>	<p>23834013</p>  <ul style="list-style-type: none"> • Montage- und Transporthalter Pos.3/4 • Assembly and transport holder 	<p>C23834013</p> <p>IC PTO L IC PTO R</p>

11659GHH 	<ul style="list-style-type: none">• Festkupplung Storz B 3" AG ALU• Storz coupling B 3" male thread, alum.• Accouplement Storz B• Accoppiamento Storz B• Koppeling Storz B	11659 Alle Typen All types Toutes var. Tutti versioni Allen typen
22480693 	<ul style="list-style-type: none">• Blindeckel mit Kette Storz B• Blind cap with chain Storz B• Couvercle aveugle avec chaîne Storz B• Coperchio con catena Storz B• Blindkap met ketting Storz B	C22480693 Alle Typen All types Toutes var. Tutti versioni Allen typen
22909931 	<ul style="list-style-type: none">• Festkupplung mit Arretierung LM franz. Gr. 80 3" AG• Coupling LM French size 80 male thread	C22909931 Alle Typen All types Toutes var. Tutti versioni Allen typen
22914147 	<ul style="list-style-type: none">• Festkupplung, Blindeckel LM franz. Gr. 80• Blind cap LM French size 80• Couvercle aveugle LM dim. francaise 80• Coperchio LM francese dim. 80• Koppeling met blindkap Frans maat 80	C22914147 Alle Typen All types Toutes var. Tutti versioni Allen typen
23875958 	<ul style="list-style-type: none">• Reibkupplung RCP40 800Nm• Friction coupling RCP40 800Nm	C23875958 Alle Typen All types Toutes var. Tutti versioni Allen typen
23308059 	<ul style="list-style-type: none">• Distanzring DN40 x 60 x 5mm für Reibkupplung RCP40• Spacer DN40 x 60 x 5mm for friction coupling RCP40	C23308059 Alle Typen All types Toutes var. Tutti versioni Allen typen

<p>23641368</p>  <ul style="list-style-type: none"> • Überlastkupplung Typ W37-B grün (g) • Shear bolt coupling 	<p>C23641368</p> <p>Alle Typen All types Toutes var. Tutti versioni Allen typen</p>	<p>22626568</p>  <ul style="list-style-type: none"> • Gelenkwellenflansch DIN 100-6/8 d=40H7 • Companion flange 	<p>C22626568</p> <p>Alle Typen All types Toutes var. Tutti versioni Allen typen</p>
<p>23462385</p>  <ul style="list-style-type: none"> • Scherbolzen, 1 Stück, grün (g) • Shear bolt, 1 piece, green (g) 		<p>C23462385</p> <p>Alle Typen All types Toutes var. Tutti versioni Allen typen</p>	
<p>23542343</p> 	<p>C23542343</p> <ul style="list-style-type: none"> • Druckschalldämpfer ohne Rückschlagklappe • Discharge silencer without non-return valve • Silencieux de refoulement • Silenziatore pressione • Persdemper 		<p>C23542343</p> <p>Interims kit</p>
<p>23402357</p>  <ul style="list-style-type: none"> • Distanzstück 110x110x60 • Spacer 	<p>C23402357</p> <p>Interims kit</p>	<p>22487623</p>  <ul style="list-style-type: none"> • Gewindestopfen 1,5" • Thread plug 	<p>C22487623</p> <p>Interims kit</p>
<p>23405376</p> 	<p>C23405376</p> <ul style="list-style-type: none"> • Rückschlagventil VA-Cromax R 3,0" IG FKM • Non-return valve • Soupape anti-retour • Valvola di non-ritorno • Terugslagklep 		<p>C23405376</p> <p>Interims kit</p>
<p>23210610</p>  <ul style="list-style-type: none"> • Krümmer, druckseitig 210mm • Manifold, discharge side 	<p>C23210610</p> <p>Interims kit</p>	<p>23518970</p>  <ul style="list-style-type: none"> • Krümmer für Hydraulik-Antrieb • Manifold for hydraulic drive 	<p>C23518970</p> <p>Hydraulic kit</p>

<p>23594740</p> 	<p>C23594740</p> <ul style="list-style-type: none"> • Anschlussglocke Hydraulikmotor • Trunk for hydraulic motor 	<p>C23594740</p> <p>Hydraulic kit</p>	
<p>23928021</p>  <ul style="list-style-type: none"> • Fingerschutz • Finger guard 	<p>C23928021</p> <p>Hydraulic kit</p>		
<p>23500762</p> 	<p>C23500762</p> <ul style="list-style-type: none"> • Kupplung, drehelastisch, vorgebohrt • Coupling, torsionally flexible, pre-bored 	<p>C23500762</p> <p>Hydraulic kit</p>	
<p>23497480</p>  <ul style="list-style-type: none"> • Rohr ALU DN130x3 L=80mm • Pipe, alum. 	<p>C23497480</p> <p>Alle Typen All types Toutes var. Tutti versioni Allen typen</p>	<p>23680630</p>  <ul style="list-style-type: none"> • Rohr ALU DN125x3 L=150mm • Pipe, alum. 	<p>C23680630</p> <p>Interims kit</p>
<p>23684657</p> 	<p>C23684657</p> <ul style="list-style-type: none"> • Rundstahlbügel DN125 M16, verzinkt • Round steel bow DN125 M16, zinc coated 	<p>C23684657</p> <p>Alle Typen All types Toutes var. Tutti versioni Allen typen</p>	
<p>22741946</p>  <ul style="list-style-type: none"> • Spiralschlauch DN125 • Flexible hose • Tuyaux flexible • Tubo flessibile • Spiraalslang 	<p>C22741946</p> <p>Alle Typen All types Toutes var. Tutti versioni Allen typen</p>	<p>23280258</p>  <ul style="list-style-type: none"> • Spiralschlauch DN130 • Flexible hose • Tuyaux flexible • Tubo flessibile • Spiraalslang 	<p>C23280258</p> <p>Light PTO L Light PTO R Interims kit</p>

23501547

63479000



- Ölansaugsieb
- Oil suction filter
- Filtre d'huile admettre
- Filtro d'olio
- Olieanzuigfilter

CS104

23200504

C23200504



- Deckel mit Entlüftung
- Cap with breather

CS104



Kompressoren

Compressors / Compresseurs /

Compressori / Compressors

95439000GHRS **RS95439000**



- Reparatur-Kompressor Typ CG80R
- Reconditioned compressor type CG80R
- Compresseur réparation model CG80R
- Compressore rigenerato tipo CG80R
- Ruilcompressor revisie model CG80R

CG600

63440000GHRS **RS63440000**



- Reparatur-Kompressor Typ CS80R/1
- Reconditioned compressor type CS80R/1
- Compresseur réparation model CS80R/1
- Compressore rigenerato tipo CS80R/1
- Ruilcompressor revisie model CS80R/1

CS700

83903990GHRS **RS83903990**



- Reparatur-Kompressor Typ CS85
- Reconditioned compressor type CS85
- Compresseur réparation model CS85
- Compressore rigenerato tipo CS85
- Ruilcompressor revisie model CS85

CS1050

Accessory kits for airends



- **22760276** accessory kit for CG80R (old 83904108)
- **22760342** accessory kit for CS80R/1–3 (old 83904109)
- **22760359** accessory kit for CS80/4 (old 83904116)
- **22760375** accessory kit for CS85 (old 83904450)

CG600
 CS700
 CS1050

Reconditioned CS104 with oil cooler **Reconditioned CS104 without oil cooler**



- **23072168RS**: CS104R1 (old RSC23072168)
- **23072176RS**: CS104L1 (old RSC23072176)

CS1200



- **23397888RS**: CS104R2 (old RSC23397888)
- **23397896RS**: CS104L2 (old RSC23397896)

CS1200









HINWEIS / NOTE / INDICATION / INDICAZIONE / OPMERKING

- Alle Reparatur-Kompressoren werden mit passender Füllmenge Silol sowie saug- und druckseitiger Dichtung geliefert.
- Reconditioned compressors are delivered with one filling of lubricant Silol and with suction and discharge gaskets.
- Tous les compresseurs „échange-standard“ seront livrés avec la quantité d’huile nécessaire et suffisante pour la machine.
- Tutti i compressori rigenerati vengono forniti con la quantità adatta di Silol e con due guarnizioni di tenuta.
- Alle revisiecompressoren worden geleverd incl. de bijbehorende hoeveelheid Silol en pakkingen voor aanzuig en perszijde.

Kompressorzubehör

*Accessories / Accessoires /
Accessori / Toebehoren*

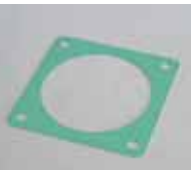

<p>37600775GHH</p> 	<ul style="list-style-type: none"> • Flachdichtung saugseitig 1,5mm dick DN80 • Flat gasket, suction side • Joint de bride côté aspiration • Guarnizione • Pakking 	<p>37600775</p> <p>CG80R CS80</p>
<p>37600776GHH</p> 	<ul style="list-style-type: none"> • Flachdichtung druckseitig 2,0mm dick DN70 • Flat gasket, discharge side • Joint de bride côté refoulement • Guarnizione • Pakking 	<p>37600776</p> <p>CG80R CS80</p>
<p>83904492GHH</p> 	<ul style="list-style-type: none"> • Flachdichtung saugseitig 1,5mm dick DN100 • Flat gasket, suction side • Joint de bride côté aspiration • Guarnizione • Pakking 	<p>83904492</p> <p>CS85</p>
<p>83904493GHH</p> 	<ul style="list-style-type: none"> • Flachdichtung CS85 druckseitig 2,0mm dick DN80 (auch verwendbar für CS1200 Krümmer 23826548, 23210610, 23518970) • Flat gasket CS85, discharge side (also usable for CS1200 manifolds 23826548, 23210610, 23518970) • Joint de bride côté refoulement • Guarnizione • Pakking 	<p>83904493</p> <p>CS85</p>
<p>23200942</p> 	<p>C23200942</p> <ul style="list-style-type: none"> • Flachdichtung saugseitig • Flat gasket, suction side • Joint de bride côté aspiration • Guarnizione • Pakking <p>CS104</p>	<p>23200959</p>  <ul style="list-style-type: none"> • Flachdichtung druckseitig • Flat gasket, discharge side • Joint de bride côté refoulement • Guarnizione • Pakking <p>CS104</p>
<p>24050122</p> 	<p>C24050122</p> <ul style="list-style-type: none"> • Flachdichtung, saugseitig • Flat gasket, suction side • Joint de bride côté aspiration • Guarnizione • Pakking <p>CS90</p>	<p>24054306</p>  <ul style="list-style-type: none"> • Flachdichtung, druckseitig • Flat gasket, discharge side • Joint de bride côté refoulement • Guarnizione • Pakking <p>CS90</p>

Accessory kits for airends



- **22760276** accessory kit for CG80R (old 83904108)
- **22760342** accessory kit for CS80R/1–3 (old 83904109)
- **22760359** accessory kit for CS80/4 (old 83904116)
- **22760375** accessory kit for CS85 (old 83904450)

CG600
CS700
CS1050

95433000GHH

95433000



- Ölansaugsieb
- Oil intake filter
- Filtre d'huile admettre
- Filtro d'olio
- Olieaanzuigfilter

CG80R

23501547

63479000



- Ölansaugsieb
- Oil suction filter
- Filtre d'huile admettre
- Filtro d'olio
- Olieaanzuigfilter

CS80
CS90
CS104

24499600

83903205



- Ölansaugsieb
- Oil intake filter
- Filtre d'huile admettre
- Filtro d'olio
- Olieaanzuigfilter

CS85

83904112GHH

83904112



- Ölmesstab
- Oil dipstick
- Jauge de niveau d'huile
- Astina di livello d'olio
- Oliepeilstok

CG80R

83904113GHH

83904113



- Ölmesstab
- Oil dipstick
- Jauge de niveau d'huile
- Astina di livello d'olio
- Oliepeilstok

CS80R

79007000GHH

79007000



- Ölmesstab
- Oil dipstick
- Jauge de niveau d'huile
- Astina di livello
- Oliepeilstok

CS80/4

83903982GHH

83903982



- Ölmesstab
- Oil dipstick
- Jauge de niveau d'huile
- Astina di livello d'olio
- Oliepeilstok

CS85

23200504

C23200504



- Deckel mit Entlüftung
- Cap with breather

CS90
CS104

83903622GHH

83903622



- Kit-Abdichtung/
Antriebswelle
- Sealing Kit/drive shaft
- Kit joint/arbre de
transmission
- Kit di tenuta/albero di
trasmissione
- Afdichtingskit/aandrijf-
fas

CG80R











83903623GHH

83903623













- Kit-Abdichtung/
Antriebswelle
- Sealing kit/drive shaft
- Kit joint/arbre de
transmission
- Kit di tenuta/albero di
trasmissione
- Afdichtingskit/aandrijf-
fas

CS80

<p>23108350</p>  <ul style="list-style-type: none"> • Kit-Abdichtung/Antriebswelle • Sealing Kit/drive shaft • Kit joint/arbre de transmission • Kit di tenuta/albero di trasmissione • Afdichtingskit/aandrijfvas 	<p>C23108350</p> <p>CS85</p>	<p>24900078</p>  <ul style="list-style-type: none"> • Kit-Abdichtung/Antriebswelle • Sealing Kit/drive shaft • Kit joint/arbre de transmission • Kit di tenuta/albero di trasmissione • Afdichtingskit/aandrijfvas 	<p>C24900078</p> <p>CS90</p>
<p>24226508</p>  <ul style="list-style-type: none"> • Kit-Abdichtung/Antriebswelle • Sealing Kit/drive shaft • Kit joint/arbre de transmission • Kit di tenuta/albero di trasmissione • Afdichtingskit/aandrijfvas 	<p>C24226508</p> <p>CS104R</p>	<p>24227076</p>  <ul style="list-style-type: none"> • Kit-Abdichtung/Antriebswelle • Sealing kit/drive shaft • Kit joint/arbre de transmission • Kit di tenuta/albero di trasmissione • Afdichtingskit/aandrijfvas 	<p>C24227076</p> <p>CS104L</p>
<p>23276900</p>  <ul style="list-style-type: none"> • Kit Ölansaugleitung, unten • Kit oil supply, bottom • Kit aspiration d'huile, à bas • Kit condotta d'olio, parte inferiore • Kit olieaanzuigleiding, onder 	<p>C23276900</p> <p>CG80R</p>	<p>22526156</p>  <ul style="list-style-type: none"> • Kit Ölversorgung • Kit oil supply • Kit approvisionnement d'huile • Kit approvviggonamento dell'olio • Kit olielulpijp 	<p>C22526156</p> <p>CG80R</p>
<p>22787980</p>  <ul style="list-style-type: none"> • Rohrfedermanometer für Öldruck 0–4 bar • Oil pressure gauge • Manomètre de pression d'huile • Manometro pressione olio • Oliedrukmeter 	<p>C22787980</p> <p>Alle Typen All types Toutes var. Tutti versioni Allen typen</p>	<p>23366925</p>  <ul style="list-style-type: none"> • Manometer 0–3–16 bar • Pressure gauge • Manomètre • Manometro • Manometer 	<p>C23366925</p> <p>Alle Typen All types Toutes var. Tutti versioni Allen typen</p>
<p>83903302GHH</p>  <ul style="list-style-type: none"> • Wartungsanzeiger • Maintenance indicator • Indicateur d'entretien • Indicatore per manutenzione • Onderhoudsindicator 	<p>83903302</p> <p>Alle Typen All types Toutes var. Tutti versioni Allen typen</p>		
<p>22200000GHH</p>  <ul style="list-style-type: none"> • Sperrschraube für Ölkanal M14x1,5x30mm • Blocking screw for oil duct • Boulon de fermeture pour canal d'huile • Bullone per canale d'olio • Blokeerbout voor oliekanal 	<p>22200000</p> <p>CS80</p>	<p>83902425GHH</p>  <ul style="list-style-type: none"> • Sperrschraube für Ölkanal G 1/4x50 • Blocking screw for oil duct • Boulon de fermeture pour canal d'huile • Bullone per canale d'olio • Blokeerbout voor oliekanal 	<p>83902425</p> <p>CS85</p>

<p>11697GHH</p>  <ul style="list-style-type: none"> • Ölkühler T1 mit Lüfter 24 Volt • Oil cooler T1 with fan 24 Volt 	<p>11697</p> <p>Remote oil cooler</p>	<p>13436GHH</p>  <ul style="list-style-type: none"> • Reduzierschraubung RI 1" ED-1/4 • Reducer fitting 	<p>13436</p> <p>Remote oil cooler</p>
<p>22669055</p>  <ul style="list-style-type: none"> • Einschraubverschraubung, gerade GE 10-PLR-1/4 ED • Plug and socket connection, straight 	<p>C22669055</p> <p>Remote oil cooler</p>	<p>37600959GHH</p>  <ul style="list-style-type: none"> • Ölablassventil Gewindeanschluss M20x1,5 • Oil drain valve • Soupape vider huile • Valvola per l'olio • Olie aflatventiel 	<p>37600959</p> <p>Optional</p>
<p>23540040</p>  <ul style="list-style-type: none"> • Konservierungs-Kit für 3 Anwendungen • Preservation kit for 3 applications 	<p>C23540040</p> <p>CG80R CS80</p>	<p>C23540057</p>  <ul style="list-style-type: none"> • Konservierungs-Kit für 3 Anwendungen • Preservation kit for 3 applications 	<p>C23540057</p> <p>CS85</p>
<p>48861629</p>  <ul style="list-style-type: none"> • Konservierungs-Kit für 3 Anwendungen • Preservation kit for 3 applications 	<p>C48861629</p> <p>CS90</p>	<p>23540065</p>  <ul style="list-style-type: none"> • Konservierungs-Kit für 3 Anwendungen • Preservation kit for 3 applications 	<p>C23540065</p> <p>CS104</p>
<p>24755076</p>  <ul style="list-style-type: none"> • Halter für Luftfilter Europiclou am Fahrzeug • Holder for air filter Europiclou on truck • Cadre support pour filtre d'air • Manicotti per filtro aria • Luchtfiltersleunen voor luchtfiler 	<p>C24755076</p> <p>Optional</p>	<p>24756819</p>  <ul style="list-style-type: none"> • Halter mit Rohr für Druckausgang 2,5" • Holder with pipe for discharge port 2.5" 	<p>C24756819</p> <p>Optional</p>
<p>47592868001</p>  <ul style="list-style-type: none"> • Stahlflexschlauch 840mm 2,5" druckseitig zur Innenmontage, 180° Bogen • Steel flex hose 2.5" 840mm discharge side for internal assembly, 180° elbow 	<p>N/A</p> <p>Optional</p>	<p>47594480001</p>  <ul style="list-style-type: none"> • Stahlflexschlauch 420mm 2,5" druckseitig zur Außenmontage, 90° Bogen • Steel flex hose 2.5" 420mm discharge side for external assembly, 90° elbow 	<p>N/A</p> <p>Optional</p>

<p>79653000GHH</p>  <ul style="list-style-type: none"> • Filterpatrone für Luftansaugfilter • Filter cartridge for suction air filter • Element filtrant pour filtre d'aspiration d'air • Cartucce per filtro • Filterelement voor aanzuigfilter 	<p>79653000</p> <p>for part no. 79652000 (old)</p>	<p>24059263</p>  <ul style="list-style-type: none"> • Luftfilter PSD 9-13m³/min (vertikal, 90° Anschluss) • Air filter PSD 9-13m³/min (vertical, 90° stop angle) 	<p>C24059263</p> <p>Optional</p>
<p>24865073</p>  <ul style="list-style-type: none"> • Filterpatrone für PSD-Serie (9-13m³/min) • Filter cartridge for PSD series • Element filtrant pour PSD • Cartucce per filtro aria PSD • Filterelement voor PSD 	<p>C24865073</p> <p>Optional</p>	<p>23840085</p>  <ul style="list-style-type: none"> • Luftfilter PSD 12-18m³/min (vertikal) • Air filter PSD 12-18m³/min (vertical) 	<p>C23840085</p> <p>Optional</p>
<p>24023723</p>  <ul style="list-style-type: none"> • Luftfilter PSD 12-18m³/min (vertikal, 90° Anschluss) • Air filter PSD 12-18m³/min (vertical, 90° stop angle) 	<p>C24023723</p> <p>Optional</p>	<p>24028169</p>  <ul style="list-style-type: none"> • Filterpatrone für PSD-Serie (12-18m³/min) • Filter cartridge for PSD series • Element filtrant pour PSD • Cartucce per filtro aria PSD • Filterelement voor PSD 	<p>C24028169</p> <p>Optional</p>
<p>47533863001</p>  <ul style="list-style-type: none"> • Wartungsanzeiger • Maintenance indicator • Indicateur d'entretien • Indicatore per manutenzione • Onderhoudsindicator 	<p>N/A</p> <p>Optional</p>	<p>22968911</p>  <ul style="list-style-type: none"> • Luftansaugfilter Europiclön mit Regenkappe (12 m³/min.) • Suction air filter Europiclön with rain cap 	<p>C22968911</p> <p>Optional</p>
<p>22968929</p>  <ul style="list-style-type: none"> • Halter für Luftfilter 22968911 • Holder for air filter • Cadre support pour filtre d'air • Manicotti per filtro aria • Luchtfitersteunen voor luchtfiter 	<p>C22968929</p> <p>Optional</p>	<p>24482382</p>  <ul style="list-style-type: none"> • Konsolenhalter für Luftfilterhalter 22968929 • Bracket holder for air filter holder 22968929 	<p>C24482382</p> <p>Light R-PTO L</p>
<p>22968937</p>  <ul style="list-style-type: none"> • Filterpatrone für Luftfilter 22968911 • Filter cartridge for air filter • Element filtrant pour filtre d'air • Cartucce per filtro aria • Filterelement voor luchtfiter 	<p>C22968937</p> <p>Optional</p>	<p>24482564</p>  <ul style="list-style-type: none"> • Zyklonvorfilter d=102mm 9,5m³/min • Cyclone pre-filter d=102mm 9,5m³/min 	<p>C24482564</p> <p>Optional</p>

<p>23266562</p>  <ul style="list-style-type: none"> • Luftansaugfilter Europiclön mit Regenkappe (15 m³/min.) • Suction air filter Europiclön with rain cap 	<p>C23266562</p> <p>Optional</p>	<p>23266604</p>  <ul style="list-style-type: none"> • Halter für Luftfilter 23266562 • Holder for air filter • Cadre support pour filtre d'air • Manicotti per filtro aria • Luchtfiltersteunen voor luchtfilter 	<p>C23266604</p> <p>Optional</p>
<p>23536089</p>  <ul style="list-style-type: none"> • Filterpatrone für Luftfilter 23266562 • Filter cartridge for air filter • Element filtrant pour filtre d'air • Cartucce per filtro aria • Filterelement voor luchtfilter 	<p>C23536089</p> <p>Optional</p>		
<p>83904257GHH</p>  <ul style="list-style-type: none"> • Luftansaugfilter Europiclön mit Regenkappe (21 m³/min.) • Suction air filter Europiclön with rain cap 	<p>83904257</p> <p>Optional</p>	<p>83904258GHH</p>  <ul style="list-style-type: none"> • Halter für Luftfilter 83904257GHH • Holder for air filter • Cadre support pour filtre d'air • Manicotti per filtro aria • Luchtfiltersteunen voor luchtfilter 	<p>83904258</p> <p>Optional</p>
<p>83904259GHH</p>  <ul style="list-style-type: none"> • Filterpatrone für Luftfilter 83904257GHH • Filter cartridge for air filter 83904257 	<p>83904259</p> <p>Optional</p>		
<p>23280233</p>  <ul style="list-style-type: none"> • Spiralschlauch DN100 • Flexible hose • Tuyaux flexible • Tubo flessibile • Spiraalslang 	<p>C23280233</p>	<p>22480602</p>  <ul style="list-style-type: none"> • Spiralschlauch DN110 • Flexible hose • Tuyaux flexible • Tubo flessibile • Spiraalslang 	<p>C22480602</p>
<p>23280241</p>  <ul style="list-style-type: none"> • Spiralschlauch DN120 • Flexible hose • Tuyaux flexible • Tubo flessibile • Spiraalslang 	<p>C23280241</p>	<p>22741946</p>  <ul style="list-style-type: none"> • Spiralschlauch DN125 • Flexible hose • Tuyaux flexible • Tubo flessibile • Spiraalslang 	<p>C22741946</p>

23280258	C23280258	 <ul style="list-style-type: none"> • Spiralschlauch DN130 • Flexible hose • Tuyaux flexible • Tubo flessibile • Spiraalslang
-----------------	------------------	---

22682132	C22682132	 <ul style="list-style-type: none"> • Schlauchschelle 90–110 • Hose clip • Collier de serrage • Cravatta fermatubi • Slangeklem
-----------------	------------------	---

33222002GHH	33222002	 <ul style="list-style-type: none"> • Schlauchschelle 100–120 • Hose clip • Collier de serrage • Cravatta fermatubi • Slangeklem
--------------------	-----------------	---

22480834	C22480834	 <ul style="list-style-type: none"> • Schlauchschelle 110–130 • Hose clip • Collier de serrage • Cravatta fermatubi • Slangeklem
-----------------	------------------	---

23497530	C23497530	 <ul style="list-style-type: none"> • Schlauchschelle 120–140 • Hose clip • Collier de serrage • Cravatta fermatubi • Slangeklem
-----------------	------------------	--

Collar bolts			
	<ul style="list-style-type: none"> • 24580177 M14x1,5; 5x40 • 24580144 M14x1,5; 5x45 • 24580136 M14x1,5; 5x50 • 24580151 M14x1,5; 5x55 • 24580169 M14x1,5; 5x60 • 24609919 M14x1,5; 5x65 • 24580276 M14x1,5; 5x70 • 24580284 M14x1,5; 5x80 • 24580292 M14x1,5; 5x90 • 24580300 M14x1,5; 5x100 	<ul style="list-style-type: none"> (old C24580177) (old C24580144) (old C24580136) (old C24580151) (old C24580169) (old C24609919) (old C24580276) (old C24580284) (old C24580292) (old C24580300) 	<ul style="list-style-type: none"> • 24580227 M16x1,5; 5x40 • 24580219 M16x1,5; 5x45 • 24580235 M16x1,5; 5x50 • 24609927 M16x1,5; 5x55 • 24610149 M16x1,5; 5x60 • 24580243 M16x1,5; 5x70 • 24580250 M16x1,5; 5x80 • 24580268 M16x1,5; 5x90 <ul style="list-style-type: none"> (old C24580227) (old C24580219) (old C24580235) (old C24609927) (old C24610149) (old C24580243) (old C24580250) (old C24580268)

Collar nuts			
	<ul style="list-style-type: none"> • 24580193 M14x1,5; 10.9 • 24580201 M16x1,5; 10.9 	<ul style="list-style-type: none"> (old C24580193) (old C24580201) 	

24304727	C24304727	 <ul style="list-style-type: none"> • Rahmenverstärkungs-Kit für Mercedes Actros 4; bis Radstand 3700 mm • Frame strengthening kit for Mercedes Actros 4; wheel base 3700 mm
-----------------	------------------	---

24304735	C24304735	 <ul style="list-style-type: none"> • Rahmenverstärkungs-Kit für Mercedes Actros 4; bis Radstand 4000 mm • Frame strengthening kit for Mercedes Actros 4; wheel base 4000 mm
-----------------	------------------	--

23250681

C23250681



- Gummi-Bogen 90° Di=100 ohne Anschluss M10x1
- Rubber elbow 90° Di=100 without adapter M10x1

24585739

C24585739



- Gummi-Bogen 90° Di=110 ohne Anschluss M10x1
- Rubber elbow 90° Di=110 without adapter M10x1

23381098

C23381098



- Gummi-Bogen 90° Di=130 ohne Anschluss M10x1
- Rubber elbow 90° Di=130 without adapter M10x1

23685548

C23685548



- Gummi-Bogen 90° Di=130 mit Anschluss M10x1
- Rubber elbow 90° Di=130 with adapter M10x1

23394497

C23394497



- Gummi-Bogen 90° Di=101,5
- Rubber elbow

23062805

C23062805



- Gummi-Muffe Di=101,5 x L=133,5
- Rubber sleeve

24306599

C24306599



- Gummi-Muffe Di=127,0 x L=152,5
- Rubber sleeve

23034937

C23034937



- Gummi-Reduzierstück 127.0/101.5 x 152.5
- Rubber reducer

23686090 	<ul style="list-style-type: none">• Gummibogen 45° Di=127• Rubber elbow	C23686090
22812945 	<ul style="list-style-type: none">• Gummi Reduzierbogen 90° 127,0 / 101,6• Rubber reducer elbow	C22812945
23497480  <ul style="list-style-type: none">• Rohr ALU DN130x3 L=80mm• Pipe, alum.	C23497480	23680630  <ul style="list-style-type: none">• Rohr ALU DN125x3 L=150mm• Pipe, alum. C23680630
23270804  <ul style="list-style-type: none">• Rohr ALU 110x5 (lfd. m.)• Pipe, alum. (per meter)	C23270804	23685555  <ul style="list-style-type: none">• Rohr ALU 130x3 (lfd. m.)• Pipe, alum. (per meter) C23685555
23420748  <ul style="list-style-type: none">• HT Rohr DN110 (lfd. m.)• HT-pipe (per meter)	C23420748	23420763  <ul style="list-style-type: none">• HT Rohr DN125 grau (lfd. m.)• HT-pipe (per meter) C23420763

22484984 **C22484984**



- Kupplung Storz B 2.5" AG
- Coupling Storz B 2.5" male thread
- Accouplement Storz B
- Accoppiamento Storz B
- Koppeling Storz B

22480701 **C22480701**



- Kupplung Storz B 2,5" IG
- Coupling Storz B 2.5" female thread
- Accouplement Storz B
- Accoppiamento Storz B
- Koppeling Storz B

11659GHH **11659**



- Kupplung Storz B 3" AG
- Coupling Storz B 3" male thread
- Accouplement Storz B
- Accoppiamento Storz B
- Koppeling Storz B

11660GHH **11660**



- Kupplung Storz B 3" IG
- Coupling Storz B 3" female thread
- Accouplement Storz B
- Accoppiamento Storz B
- Koppeling Storz B

22480693 **C22480693**



- Blinddeckel m. Kette Storz B
- Blind cap with chain Storz B
- Couvercle aveugle avec chaîne Storz B
- Coperchio c. catena Storz B
- Blindkap met ketting Storz B

22952329 **C22952329**



- Festkupplung LM franz. Gr. 80 mit Arretierung 2,5" AG
- Coupling LM French size 80 with catch male thread

22952337 **C22952337**



- Festkupplung LM franz. Gr. 80 ohne Arretierung 2,5" IG
- Coupling LM French size 80 without catch female thread

22909931 **C22909931**



- Festkupplung LM franz. Gr. 80 mit Arretierung 3" AG
- Coupling LM French size 80 without catch male thread

22909949 **C22909949**



- Festkupplung LM franz. Gr. 80 mit Arretierung 3" IG
- Coupling LM French size 80 without catch female thread

22914147 **C22914147**



- Festkupplung, Blinddeckel LM franz. Gr. 80
- Blind cap LM French size 80
- Couvercle aveugle LM dim. française 80
- Coperchio LM francese dim. 80
- Koppeling met blindkap Frans maat 80

13674GHH **13674**



- Kurvenstück TW 518 R 2,5" IG
- Male tank wagon coupling, TW 518 R 2,5" IG

Light

11663GHH **11663**



- Blinddeckel 3" TW 506
- Blind cap 3" TW 506

Light



Schmierstoffe

Lubricants / Huiles /

Lubrificanti / Smeermiddelen

83903817GHH

83903817



- Hochleistungsöl Silol im Karton (2 x 5 Liter)
- Container of Silol lubricant (2 x 5 ltr.)
- Lubrifiant Silol box (2 x 5 ltr.)
- Lubrificante Silol confezione (2 x 5 litri)
- Hoogwaardige olie Silol verpakking (2 x 5 liter)

23525884

C23525884



- Hochleistungsöl Silol im Karton (1 x 5 Liter)
- Container of Silol lubricant (1 x 5 ltr.)
- Lubrifiant Silol box (1 x 5 ltr.)
- Lubrificante Silol confezione (1 x 5 litri)
- Hoogwaardige olie Silol verpakking (1 x 5 liter)

83903818GHH

83903818



- Hochleistungsöl Silol im Fass (205 Liter)
- Barrel of Silol lubricant (205 ltr.)
- Baril de lubrifiant Silol (205 ltr.)
- Fusto di lubrificante Silol (205 litri)
- Vat hoogwaardige olie Silol (205 liter)

24545246

C24545246







- Hochleistungsöl Silol FG (lebensmitteltauglich) im Karton (1 x 5l.)
- Lubricant Silol food grade in a box (1 x 5 ltr.)
- Lubrifiant Silol FG box (1 x 5 ltr.)
- Lubrificante Silol FG confezione (1 x 5 litri)
- Hoogwaardige olie FG Silol (1 x 5 ltr.)

23057557

C23057557



- Hochleistungsöl Silol FG (lebensmitteltauglich) im Fass (208 Liter)
- Barrel of Silol FG lubricant (208 ltr.)
- Baril de lubrifiant Silol FG (208 ltr.)
- Fusto di lubrificante Silol FG (208 litri)
- Vat hoogwaardige olie FG Silol (208 liter)

23013790		<ul style="list-style-type: none"> • Silol FG Spülschmiermittel im Karton (2 x 5 Liter) • Silol FG flushing lubricant in a box (2 x 5 ltr.) • Silol FG lubrifiant de lavage box (2 x 5 ltr.) • Silol FG lubrificante di lavaggio confezione (2 x 5 litri) • Silol FG spoelsmeermiddel (2 x 5 ltr.) 	C23013790
23263064		<ul style="list-style-type: none"> • Silol FG Spülschmiermittel-Kit • Silol FG flushing lubricant kit • Silol FG kit lubrifiant de lavage • Silol FG kit lubrificante di lavaggio • Silol FG spoelkit 	C23263064
23263072		<ul style="list-style-type: none"> • Silol FG Spülschmiermittel-Kit • Silol FG flushing lubricant kit • Silol FG kit lubrifiant de lavage • Silol FG kit lubrificante di lavaggio • Silol FG spoelkit 	C23263072
23263080		<ul style="list-style-type: none"> • Silol FG Spülschmiermittel-Kit • Silol FG flushing lubricant kit • Silol FG kit lubrifiant de lavage • Silol FG kit lubrificante di lavaggio • Silol FG spoelkit 	C23263080
24258089		<ul style="list-style-type: none"> • Silol FG Spülschmiermittel-Kit • Silol FG flushing lubricant kit • Silol FG kit lubrifiant de lavage • Silol FG kit lubrificante di lavaggio • Silol FG spoelkit 	C24258089
			CS580 / CS750 / CS1200

Keilriemen

V-belts / Courroies trapézoïdale / Cinghia trapezoidale / V-snaren

Keilriemenscheiben

V-belt pulleys / Poulies / Pulegge / V-snaar schijven

Taper-Lock-Buchsen

*Taper-Lock plug sockets / Taper-Lock Prise femelle /
Taper-Lock prese / Taper-Lockbussen*





Bezeichnung/description	Artikel-Nr./article no.	Alte Artikel-Nr./old article no.
XPA 800	23006398	C23006398
XPA 832	23964695	C23964695
XPA 882	23311483	C23311483
XPA 932	23614753	C23614753
XPA 1060	14182GHH	14182
XPA 1082	23038706	C23038706
XPA 1107	23328099	C23328099
XPA 1120	23047400	C23047400
XPA 1157	22880538	C22880538
XPA 1207	22828008	C22828008
XPA 1232	12238GHH	12238
XPA 1250	12159GHH	12159
XPA 1282	12162GHH	12162
XPA 1307	23081763	C23081763
XPA 1320	12164GHH	12164
XPA 1332	12165GHH	12165
XPA 1357	12166GHH	12166
XPA 1360	13467GHH	13467
XPA 1382	12167GHH	12167
XPA 1400	12168GHH	12168
XPA 1407	14242GHH	14242
XPA 1432	12169GHH	12169
XPA 1457	12170GHH	12170
XPA 1482	12171GHH	12171
XPA 1500	12172GHH	12172
XPA 1507	12173GHH	12173
XPA 1532	12174GHH	12174
XPA 1557	12175GHH	12175
XPA 1582	13454GHH	13454
XPA 1600	12177GHH	12177
XPA 1607	12178GHH	12178
XPA 1632	13746GHH	13746
XPA 1650	12179GHH	12179
XPA 1682	13339GHH	13339
XPA 1700	12176GHH	12176
XPA 1732	47527556001	N/A
XPA 1757	47527557001	N/A
XPA 1782	12216GHH	12216
XPA 1800	12217GHH	12217
XPA 1857	13048GHH	13048
XPA 1882	14446GHH	14446
XPA 1900	22924922	C22924922
XPA 2057	14807GHH	14807
XPA 2182	23186141	C23186141

Keilriemen / V-belts
 Courroies trapézoïdale / Cinghia trapezoidale / V-snaren



Bezeichnung/description	Artikel-Nr./article no.	Alte Artikel-Nr./old article no.
XPB 1030	14434GHH	14434
XPB 1250	12219GHH	12219
XPB 1320	12220GHH	12220
XPB 1400	12270GHH	12270
XPB 1450	13278GHH	13278
XPB 1500	12319GHH	12319
XPB 1550	22518286	C22518286
XPB 1600	22485502	C22485502
XPB 1650	22570568	C22570568
XPB 1700	22489843	C22489843
XPB 1720	23266752	C23266752
XPB 1750	14621GHH	14621
XPB 1800	24155475	C24155475
XPB 1850	23276975	C23276975
XPB 1900	22909006	C22909006
XPB 2000	22927768	C22927768
XPB 2020	22909014	C22909014
XPB 2650	23312168	C23312168
XPB 2680	23329857	C23329857

Keilriemenscheiben / V-belt pulleys
 Poulies / Pulegge / V-snaar schijven



Bezeichnung/description	Artikel-Nr./article no.	Alte Artikel-Nr./old article no.
SPA 125-5 TL2012	10773GHH	10773
SPA 132-5 TL2517	23937378	C23937378
SPA 140-5 TL2517	13030GHH	13030
SPA 150-5 TL2517	14180GHH	14180
SPA 160-5 TL2517	14250GHH	14250
SPA 180-5 TL3020	13920GHH	13920
SPA 200-5 TL3020 VTP	13028GHH	13028
SPA 224-5 TL3020 VTP	22937270	C22937270
SPA 250-5 TL3020 VTP	12108GHH	12108
SPA 280-5 TL3525 VTP	12582GHH	12582
SPA 315-5 TL3525 VTP	12112GHH	12112



Bezeichnung/description	Artikel-Nr./article no.	Alte Artikel-Nr./old article no.
SPB 125-5 TL2012	11818GHH	11818
SPB 140-4 TL2517	15187GHH	15187
SPB 140-5 TL2517	12811GHH	12811
SPB 150-5 TL2517	12562GHH	12562
SPB 160-4 TL2517	14907GHH	14907
SPB 160-5 TL2517	13297GHH	13297
SPB 180-4 TL2517 VTP	14429GHH	14429
SPB 180-5 TL3020	14720GHH	14720
SPB 190-5 TL3020	23385768	C23385768
SPB 200-4 TL3020	22908107	C22908107
SPB 200-5 TL3020	22409338	C22409338
SPB 224-4 TL3020 VTP	15384GHH	15384
SPB 224-5 TL3020 VTP	22554935	C22554935
SPB 250-4 TL3020 VTP	22908099	C22908099
SPB 250-5 TL3525 VTP	22554943	C22554943
SPB 280-4 TL3020 VTP	22832299	C22832299
SPB 280-5 TL3525 VTP	22554950	C22554950
SPB 315-5 TL3525 VTP	12563GHH	12563

Taper-Lock-Buchsen / Taper-Lock plug sockets
 Taper-Lock Prise femelle / Taper-Lock prese / Taper-Lockbussen



Bezeichnung/description	Artikel-Nr./article no.	Alte Artikel-Nr./old article no.
2012 - 35 mm	11561GHH	11561
2012 - 40 mm	11563GHH	11563
2517 - 35 mm	11556GHH	11556
2517 - 40 mm	12125GHH	12125
2517 - 45 mm	14846GHH	14846
3020 - 40 mm	11565GHH	11565
3020 - 45 mm	22409353	C22409353
3020 - 50 mm	22461875	C22461875
3525 - 45 mm	22409361	C22409361
3525 - 50 mm	22461883	C22461883



Flüssigkeiten

*Liquid bulk / Liquides /
Materiale fluido / Vloeistoffen*



Drehschieberkompressor

Privo d'olio sliding vane compressor

Sliding vane compressor

Compresseur à palettes

Olle vrije schotten compressor

SV120/
SV200

47582602001	N/A	
	<ul style="list-style-type: none"> • Drehschieberkompressor SV200 • Sliding vane compressor SV200 • Compresseur à palettes SV200 • Privo d'olio sliding vane compressor SV200 • Olie vrije schotten compressor SV200 	Direct drive
23203656	C23203656	
	<ul style="list-style-type: none"> • Gelenkwellenflansch DIN 100/6-8 d = 25H7 • Drive shaft flange • Joint onduler de bride • Flangia per giunto • Aandrijfflens 	Direct drive
23543812	C23543812	
	<ul style="list-style-type: none"> • Gelenkwellenflansch DIN 90-4/8 d = 25H7 • Drive shaft flange • Joint onduler de bride • Flangia per giunto • Aandrijfflens 	Direct drive
23203664	C23203664	
	<ul style="list-style-type: none"> • Gelenkwellenflansch SAE 1310 d = 25H7 • Drive shaft flange • Joint onduler de bride • Flangia per giunto • Aandrijfflens 	Direct drive
23332737	C23332737	
	<ul style="list-style-type: none"> • Gelenkwellenflansch SAE 1100 d = 25H7 • Drive shaft flange • Joint onduler de bride • Flangia per giunto • Aandrijfflens 	Direct drive
23331861	C23331861	
	<ul style="list-style-type: none"> • Flachdichtung druckseitig/saugseitig, DN40, 2,0 mm dick • Flat gasket • Joint de bride côté aspiration • Guarnizione • Paking 	Direct drive/ hydraulic drive







<p>23471881</p> 	<p>C23471881</p> <ul style="list-style-type: none"> • Überlastkupplungs-Kit Flex mit Ersatzbolzen • Shear bolt coupling with spare bolt 	<p>Direct drive</p>
<p>23392996</p> 	<p>C23392996</p> <ul style="list-style-type: none"> • Scherbolzen 1 Stück, blau/grün (b/g) • Shear bolt 1 pc., blue/green (b/g) 	<p>Direct drive</p>
<p>23331838</p> 	<p>C23331838</p> <ul style="list-style-type: none"> • Schlauchanschlussflansch DN50, 90°, drehbar • Hose connection flange DN50, 90°, swiveling • Utricule raccordement • Guarnizione per tubo • Aansluitflens voor slang 	<p>Direct drive/ hydraulic drive</p>
<p>23332182</p> 	<p>C23332182</p> <ul style="list-style-type: none"> • Flansch 1 1/2" BSP IG, Schmiedestahl • Flange, forged steel • Bride • Guarnizione • Flens 	<p>Direct drive/ hydraulic drive</p>
<p>23332190</p> 	<p>C23332190</p> <ul style="list-style-type: none"> • Schlauchanschluss 90° mit 1 1/2" AG DN50 • Hose connection • Utricule raccordement • Guarnizione per tubo • Aansluit voor slang 	<p>Direct drive/ hydraulic drive</p>
<p>23331630</p> 	<p>C23331630</p> <ul style="list-style-type: none"> • Luftansaugfilter Europiclön mit Regenkappe (3m³/min) • Suction air filter Europiclön with rain cap • Filtre d'aspiration d'air Europiclön avec chapeau contre la pluie • Filtro aspirazione aera Europiclön con coperchio • Aanzuigfilter Europiclön met regenkap 	<p>Direct drive/ hydraulic drive</p>

<p>23331648</p> 	<ul style="list-style-type: none"> • Halter für Luftfilter Europiclon (3m³/min) • Holder for air filter • Cadre support pour filtre d'air • Manicotti per filtro aria • Luchtfiltersteunen voor luchtfilter 	<p>C23331648</p> <p>Direct drive/ hydraulic drive</p>
<p>23487929</p> 	<ul style="list-style-type: none"> • Filterpatrone für Europiclon (3m³/min) • Filter cartridge for Europiclon • Element fi ltrant pour Europiclon • Cartucce per filtro aria Europiclon • Filterelement voor Europiclon 	<p>C23487929</p> <p>Direct drive/ hydraulic drive</p>
<p>23331770</p> 	<ul style="list-style-type: none"> • Gummibogen 90° Di = 50 mit Anschluss M10x1 • Rubber elbow 	<p>C23331770</p> <p>Direct drive/ hydraulic drive</p>
<p>23331796</p> 	<ul style="list-style-type: none"> • Wartungsanzeiger 50 mbar mit Innengewinde M10x1 • Maintenance indicator with female thread • Indicateur d'entretien • Indicatore per manutenzione • Onderhoudsindicator 	<p>C23331796</p> <p>Direct drive/ hydraulic drive</p>
<p>23331804</p> 	<ul style="list-style-type: none"> • Rohr ALU DN50x2 L = 80 mm • Tube, alum. 	<p>C23331804</p> <p>Direct drive/ hydraulic drive</p>
<p>23331820</p> 	<ul style="list-style-type: none"> • Schlauchanschlussflansch DN50, gerade • Hose connection flange, straight • Utricule raccordement • Guarnizione per tubo • Aansluitflens voor slang 	<p>C23331820</p> <p>Direct drive/ hydraulic drive</p>

<p>23331853</p> 	<p>C23331853</p> <ul style="list-style-type: none"> • Spiralschlauch DN50 (lfd. Meter) • Flexible hose (per meter) • Tuyaux flexible • Tubo flessibile • Spiraalslang 	<p>Direct drive/ hydraulic drive</p>
<p>33212000GHH</p> 	<p>33212000</p> <ul style="list-style-type: none"> • Schlauchschelle DIN 3017 AS 50–70, b = 12 mm • Hose clip • Collier de serrage • Cravatta fermatubi • Slangeklem 	<p>Direct drive/ hydraulic drive</p>
<p>23333685</p> 	<p>C23333685</p> <ul style="list-style-type: none"> • Anschweißflansch-Kit 1 1/2", ST37 • Welding flange kit, mild steel 	<p>Direct drive/ hydraulic drive</p>
<p>23333693</p> 	<p>C23333693</p> <ul style="list-style-type: none"> • Anschweißflansch-Kit 1 1/2", VA • Welding flange kit, stainless steel 	<p>Direct drive/ hydraulic drive</p>
<p>23333701</p> 	<p>C23333701</p> <ul style="list-style-type: none"> • Flansch-Kit 1 1/2" BSP IG, Schmiedestahl • Flange kit, forged steel • Bride fournement • Guarnizione equipaggiamento • Flens kit 	<p>Direct drive/ hydraulic drive</p>
<p>23332562</p> 	<p>C23332562</p> <ul style="list-style-type: none"> • Sicherheitsventil G 0,5" 2,5 bar, Messing • Safety relief valve • Soupape de sûreté • Valvola di sicurezza • Overdrukventiel 	<p>Direct drive/ hydraulic drive</p>

23359268	C23359268	
 A stainless steel T-piece fitting with three ports. Two ports are on the top and bottom, and one is on the side. The top and bottom ports have external threads, while the side port is smooth.	<ul style="list-style-type: none">• T-Stück VA R11/2"DIN 2987• T piece, stainless steel	Direct drive/ hydraulic drive
23359276	C23359276	
 A stainless steel reducer fitting with a hexagonal base and a threaded top. The top has a smaller diameter than the base.	<ul style="list-style-type: none">• Reduzier-Stück VA R11/2"-1/2", AG/IG• Reducer, stainless steel	Direct drive/ hydraulic drive
24046112	C24046112	
 A stainless steel non-return valve with a hexagonal base and a threaded top. The top has a smaller diameter than the base.	<ul style="list-style-type: none">• Rückschlagventil 1 1/2" IG VITON VA• Non-return valve, stainless steel• Soupape anti-retour• Valvola di non-ritorno• Terugslagklep	Direct drive/ hydraulic drive
23463227	C23463227	
 A black metal mounting bracket with a U-shaped top and a flat base. There are four mounting holes on the top and two on the base. A small pile of screws is visible next to the base.	<ul style="list-style-type: none">• Montagekonsole komplett für Direktantrieb• Bracket complete for direct drive• Console de montage avec commande• Supporto di montaggio con trasmissione• Montageconsole compleet met aandrijving	Direct drive/ hydraulic drive

<p>47582606001</p> 	<ul style="list-style-type: none"> • Drehschieberkompressor SV200, Hydraulikantrieb • Sliding vane compressor SV200, hydraulic drive • Compresseur à palettes SV200 • Privo d'olio sliding vane compressor SV200 • Olie vrije schotten compressor SV200 	<p>N/A</p> <p>Hydraulic drive</p>	
<p>23467558</p> 	<ul style="list-style-type: none"> • Flexible Kupplung Hydraulikantrieb mit C23487408 / C23487416 • Flexible coupling for hydraulic drive 	<p>C23467558</p> <p>Hydraulic drive</p>	
<p>23487424</p>  <ul style="list-style-type: none"> • Nabe für flexi. Kupplung 7/8" • Hub • Moyeu • Mozzo • Naaf 	<p>C23487424</p> <p>Hydraulic drive</p>	<p>23487432</p>  <ul style="list-style-type: none"> • Nabe für flexi. Kupplung • Hub • Moyeu • Mozzo • Naaf 	<p>C23487432</p> <p>Hydraulic drive</p>
<p>23487408</p>  <ul style="list-style-type: none"> • M-Hülse für flexi. Kupplung • M sleeve for flexible coupling 	<p>C23487408</p> <p>Hydraulic drive</p>	<p>23487416</p>  <ul style="list-style-type: none"> • Nabe für flexi. Kupplung 25H7 • Hub • Moyeu • Mozzo • Naaf 	<p>C23487416</p> <p>Hydraulic drive</p>
<p>23517378</p> 	<ul style="list-style-type: none"> • Hydraulik-Zahnradmotor-Kit 56 Ltr/min • Hydraulic gear motor kit • Moteur hydraulique à engrenages fourniment • Motoriduttore idraulico equipaggiamento • Hydraulische reductiemotor kit 	<p>C23517378</p> <p>Hydraulic drive</p>	
<p>23517386</p> 	<ul style="list-style-type: none"> • Hydraulik-Zahnradmotor-Kit 62 Ltr/min • Hydraulic gear motor kit • Moteur hydraulique à engrenages fourniment • Motoriduttore idraulico equipaggiamento • Hydraulische reductiemotor kit 	<p>C23517386</p> <p>Hydraulic drive</p>	

<p>23809536-ATO*</p> 	<ul style="list-style-type: none"> • Rohrleitungs-Kit Edelstahl 1,5", 90° Bogen, wahlweise mit Franz.-Kupplung und mit Stahlflex-Schlauch (unterschiedliche Längen) • Pipeline kit stainless steel 1,5", 90° bow, configurable with French coupling and flexible hose (several lengths) 	<p>N/A</p> <p>Direct drive/ hydraulic drive</p>
<p>23615909</p> 	<ul style="list-style-type: none"> • Rohrleitung Edelstahl 1,5", 90° Bogen, TW Kupplung VK50/MB50 • Pipeline stainless steel 1,5", 90° bow, tank wagon coupling VK50/MB50 	<p>C23615909</p> <p>Direct drive/ hydraulic drive</p>
<p>23861347</p> 	<ul style="list-style-type: none"> • Rohrleitung Edelstahl mit 1,5", 90° Bogen, Franz.-Kupplung • Pipeline stainless steel with 1,5" 90°, bow, French coupling 	<p>C23861347</p> <p>Direct drive/ hydraulic drive</p>
<p>23615891</p> 	<ul style="list-style-type: none"> • Stahlflex-Schlauch VA DN40 x 650 Ü-Mutter / 90° • Flexible hose VA DN40 x 650 nut / 90° 	<p>C23615891</p> <p>Direct drive/ hydraulic drive</p>
<p>23704836</p> 	<ul style="list-style-type: none"> • Stahlflex-Schlauch VA DN40 x 1000 Ü-Mutter / 90° • Flexible hose VA DN40 x 1000 nut / 90° 	<p>C23704836</p> <p>Direct drive/ hydraulic drive</p>
<p>23742018</p> 	<ul style="list-style-type: none"> • Stahlflex-Schlauch VA DN40 x 1150 Ü-Mutter / 90° • Flexible hose VA DN40 x 1150 nut / 90° 	<p>C23742018</p> <p>Direct drive/ hydraulic drive</p>

23638372	C23638372	
	<ul style="list-style-type: none">• Trennschieber-Kit (Satz aus 6 Stück)• Vane kit (Set of 6 pieces)	Direct drive/ hydraulic drive
23523012	C23523012	
	<ul style="list-style-type: none">• Reparatur-Kit• Repair kit	Direct drive/ hydraulic drive
23537509	C23537509	
	<ul style="list-style-type: none">• Fettkartusche 400g• Bearing grease• Graisse pour roulements• Grasso per cuscinetti• Lagervet	Direct drive/ hydraulic drive