

# GHH RAND®



## The **Next Generation** CS1200

Introducing the CS1200 Intercooled Lite (ICL) compressor package, new from GHH RAND®. The ICL features the latest generation of the CS104 air end, our slim, high efficiency air cooler and reactive discharge silencer in one compact solution. Specifically designed for the bulk transfer of temperature sensitive materials, the CS1200 ICL is controlled to discharge air as low as 50 degrees.

Ease of Installation | Temperature Controlled Discharge | Secured Product Safety



[www.oem-solutions.ingersollrand.com](http://www.oem-solutions.ingersollrand.com)

# CS1200 ICL

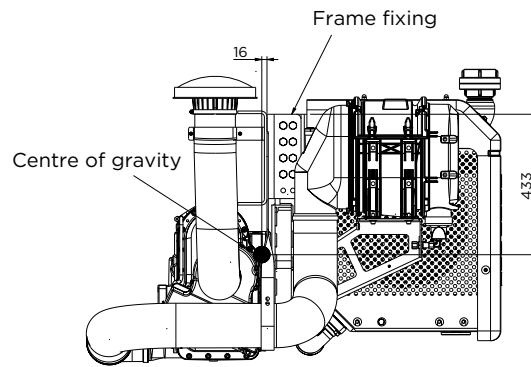
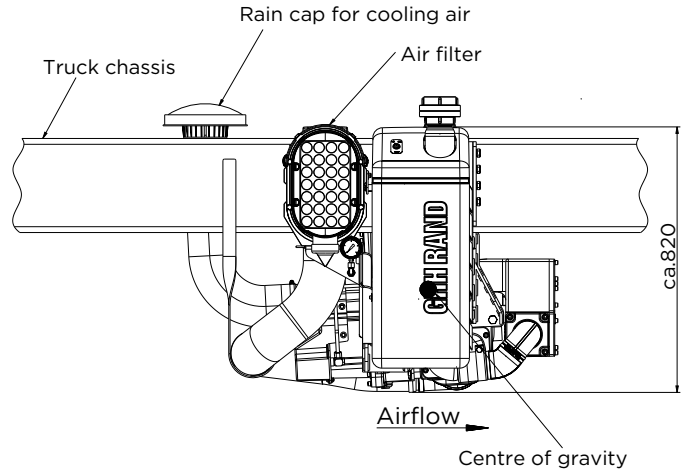
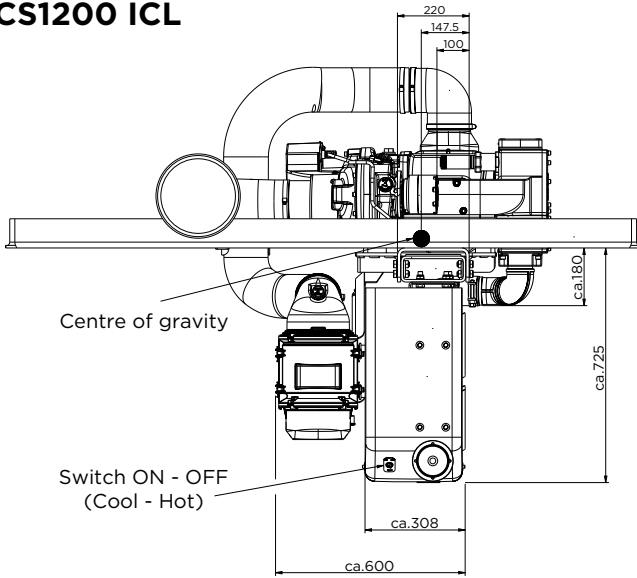

## Benefits

### Ease of Installation

A narrow footprint, combined with a variety of mounting frames results in a compressor package that can simply be bolted onto most European manufacturer's 4x2, 6x2 and 6x4 chassis rails, without the need and expense of additional fabrication.

### Temperature Controlled Discharge

Controlled cool air ensures that heat sensitive products can be discharged without fear of degradation. The GHH RAND® temperature controlled CS1200 ICL delivers peace of mind with discharged air temperature reduced to as low as 50 degrees, protecting your product.

## Applications

Manufactured specifically for Dry Bulk applications and offering flow rates of up to 1,150 m<sup>3</sup>/hr, the CS1200 ICL is optimised for use with a wide range of products including: Plastics, Sugar, Feeds and many other temperature sensitive dry bulk products.

**Secured Product Safety** – Additional safety of your discharged product is ensured with GHH RAND® oil free compression, this is achieved via a unique sealing system preventing oil contamination of the discharge air, food grade rotor coating, non-migrating media discharge silencer and FG SILOL® lubrication. All of these provide you with a solution specifically designed for the bulk discharge of temperature sensitive and food grade products.

## Technical Data

Parameter	Unit	Min.	Max.
Suction volume compressor airend	m <sup>3</sup> /h	712	1124
Input speed	min <sup>-1</sup>	1200	1800
Power consumption compressor airend	kW	39	62
Max. discharge pressure	bar(g)	2,5	

Note: Medium: air, suction temperature: 20°C, suction pressure: 1 bar (abs.), Power & Flow: 2.0 bar (g).

# GHH RAND®

Ingersoll Rand Trading GmbH

Customer Center Tanker Solutions

Max-Planck-Ring 27 • 46049 Oberhausen • Germany

Phone: +49 (0) 208 9994-0 Fax: +49 (0) 208 9994-179

Email: info@ghhrand.com

